



# Magic For All

presents.....

*Tricks in Magic, Illusions, and Mental Phenomena*

*Volume I  
J.H. Burlingame*

To see all the latest instant download magic tricks:  
[CLICK HERE](#)

To see our new magic video page just:  
[CLICK HERE](#)

To receive even more free classic magic books:  
[CLICK HERE](#)

**This version of a classic magic book was distributed by [www.learnmagictricks.org](http://www.learnmagictricks.org). You may distribute it in any way you wish, but we ask that you do so only to genuine magicians and please do not alter the ebook in any way.**

**WEBMASTERS: If you wish to distribute this ebook with a link back to your web site included, simply email: [admin@magicforall.com](mailto:admin@magicforall.com) and we will prepare a copy for you.**

# Table of Contents

## Tricks in Magic, Illusions, and Mental Phenomena

### Volume I

<u>J.H. Burlingame</u> .....	1
<u>Handkerchief Multiplication</u> .....	4
<u>Now You See it; Now You Don't; Handkerchief</u> .....	5
<u>Soup Plate and Handkerchief</u> .....	6
<u>Mephisto's Glass Cylinders</u> .....	7
<u>The Flight Through Crystals</u> .....	8
<u>The Chameleon Handkerchiefs</u> .....	9
<u>New Postal Card Trick</u> .....	11
<u>Card Nailed Between Boards</u> .....	12
<u>Demon Cards</u> .....	13
<u>Pipe Trick</u> .....	14
<u>The Wa-Ha-Gi Billiard Ball</u> .....	15
<u>Magic Die, Flowers and Glass Box</u> .....	16
<u>Ice Freezing Extraordinary</u> .....	17
<u>New Programme, Ring and Envelopes Trick</u> .....	18
<u>Bertram's Programme and Coin Trick</u> .....	20
<u>New Chair Mystery</u> .....	22
<u>How to Tell Numbers of Borrowed Watches</u> .....	23
<u>Slade's Wonderful Spirit Knots</u> .....	24
<u>Dexter's Sealed Cord Test</u> .....	25
<u>Bellachini's Cabinet Mystery</u> .....	26
<u>The Three Knotted Charmed Handkerchiefs</u> .....	27
<u>The Eglinton Rope Test</u> .....	28
<u>One of the Davenport Rope Ties</u> .....	29
<u>Braid and Tape Test</u> .....	30
<u>The Medium's Ties, Similar to No. 23</u> .....	31
<u>New Spirit Post</u> .....	32
<u>New Spirit Hand</u> .....	33
<u>The Mystery of L'Hassa</u> .....	34
<u>New Spirit Pictures</u> .....	36
<u>Shrine of Koomra Sami</u> .....	37
<u>Mysterious Cabinet of the Mahatmas or Wonder of</u> .....	38
<u>Spirit Circle Under Test Conditions</u> .....	39
<u>Great Mahatma Miracles</u> .....	40
<u>One Way of Producing Great Mahatma Miracles</u> .....	41
<u>One Method of Materialization and Dematerialization</u> .....	42
<u>Kellar's New Karmos</u> .....	43
<u>Silent Thought Transference</u> .....	45
<u>New Silent Second Sight and Bank Note Test</u> .....	53
<u>Second Sight Through Brick Walls</u> .....	56
<u>Psychonotism, or Silent Thought Transmission</u> .....	59
<u>The Spirit Thinkerphone, or Marvelous Vision</u> .....	63
<u>Taschypsiography, or Long Distance Second Sight</u> .....	65
<u>Hypnotism</u> .....	67

<a href="#"><u>The Great Shooting Act</u></a> .....	76
<a href="#"><u>Head of Ibykus, or Talking Skull</u></a> .....	77
<a href="#"><u>The Mango Tree</u></a> .....	79
<a href="#"><u>Queen of Knives</u></a> .....	80
<a href="#"><u>The Appearing Lady</u></a> .....	81
<a href="#"><u>The Escape from Sing Sing</u></a> .....	82
<a href="#"><u>Rapid Transit</u></a> .....	84
<a href="#"><u>Noah's Ark</u></a> .....	85
<a href="#"><u>The Oriental Barrel Mystery</u></a> .....	86
<a href="#"><u>The Artist's Dream</u></a> .....	88
<a href="#"><u>New Half Lady Illusion</u></a> .....	90
<a href="#"><u>Edgar Poe's Raven in the Garland of Thebes</u></a> .....	91
<a href="#"><u>Samuel's Cartomantic Floral Charm</u></a> .....	92
<a href="#"><u>Samuel's Mystic Percolator</u></a> .....	93
<a href="#"><u>Samuel's Wonder Kraut</u></a> .....	94
<a href="#"><u>Samuel's Magic Squeezers</u></a> .....	95
<a href="#"><u>Samuel's Wine Tassels</u></a> .....	96
<a href="#"><u>Samuel's Bloodstone Wonder</u></a> .....	97
<a href="#"><u>Samuel's Handkerchief Tassel</u></a> .....	98
<a href="#"><u>Samuel's Golden Flash of Light</u></a> .....	99

## ***Handkerchief Multiplication***

Get two silk handkerchiefs and put each in a small paper tube, and place each behind ear and keep in place with a small piece of wax. Show silk handkerchief and hand empty. Take handkerchief between hands by corners and lay over head. Take tubes from behind ear and produce in course of time.

## ***Now You See it; Now You Don't; Handkerchief***

This trick although simple is one of the prettiest sleight of hand feats in existence. Use a fine small silk handkerchief, between the joint and thumb and forefinger of left hand conceal a small piece of the same silk rolled up in a ball. Roll up your sleeves, show hands empty, have handkerchief examined and taking it between the hand roll it up into a ball which you pretend to pass into left hand, but really palming it in right. Let silk at rear of thumb expand in left hand, letting audience see it, they are now sure that the handkerchief is really there; meanwhile you get rid of the handkerchief proper. In due time join hands roll up the bit of silk into a ball again and press it back in its former hiding place, then show handkerchief gone and hands empty. Cause handkerchief to reappear by causing silk to expand and let it be seen, vanish the silk as described above.

## ***Soup Plate and Handkerchief***

The handkerchief is rolled up very small and is held between the soup plate and hand, while the performer is calling attention to the plate. When in the act of laying the plate down, under cover of the plate drop the handkerchief. Vanish as follows: A small ball of any suitable material about an inch in diameter and with an opening on one side of it about half an inch in diameter is attached to a wire loop. This loop is slipped over the thumb of the left hand. Performer takes a small silk handkerchief and works it into the hollow ball and under cover of the right hand slips the rubber ball over the hand and allows it to hang down at the back of left hand. Palms of both hands can now be shown empty, performer picks up soup plate in his left hand and exhibits the duplicate handkerchief underneath and holds soup plate in his left hand and under cover of the plate drops the handkerchief and vanishes on servante and carelessly calls attention to the back of the hands. This can be done very quickly.

## ***Mephisto's Glass Cylinders***

**Effect--**Two glass cylinders are shown and then placed opposite to each other on the stage. Performer borrows a dozen handkerchiefs and has them all tied together; he then places them in either cylinder, as selected by the audience. Performer now commands the handkerchiefs to vanish, which they instantly do, and appear in the other cylinder which was previously shown empty. These cylinders can also be used for the vanishing and appearing of birds, rabbits, liquors, flowers, etc., etc.

**Secret--**Have a cylinder of opaque glass about two feet high; also two shells of same colored glass which fit over the genuine cylinder that has bottom in it; also have two pedestals (imitation of marble), which are hollow; these are placed over traps in stage at each side. Assistant under stage has a long rod on one end of which is a wooden disc; this disc is a little smaller than the inside of glass shells. Performer shows shell and cylinder together, then places them on one of the pedestals; assistant pushes up rod from below so that disc is flush with top of pedestal. Performer now places the other cylinder (shell), on the second pedestal. He now borrows some handkerchiefs and has them tied together, these he places in first cylinder and, on command to vanish, assistant quickly lowers rod and disc (cylinder containing handkerchiefs is resting on disc), down, and quickly shoves it up into the shell on second pedestal, from which the performer produces the handkerchiefs. Performer steadies outer shell, by placing his wand across top of it and bearing downwards, meanwhile addressing the audience upon some point of interest, while assistant pushes up inner cylinder. Of course you must have audience imagine that both cylinders have bottoms in them.

## ***The Flight Through Crystals***

**Effect--**You hand to audience for examination, three silk handkerchiefs; one red, one white, and one blue. Next you show the two crystal cylinders, such as is used on gas jets. Have someone in audience to tie the corners of blue and white handkerchiefs together and roll them into a ball, which you place in one of the cylinders, and give to someone to hold. You next take the red handkerchief and place it in the other cylinder, and hold one hand over each end of cylinder, and away from your body. You now command the red handkerchief to vanish, and instantly the cylinder is seen empty; hands are still covering both ends. Person holding the other cylinder removes the two handkerchiefs and unrolls them, and to their astonishment they find the red handkerchief which had disappeared from the other cylinder between the blue and white handkerchiefs, all being tied together. Very effective.

**Secret--**After person has tied blue and white handkerchiefs together, you request him or her to roll handkerchiefs into a ball, rolling the white one inside of the blue one, and place ball on a plate which you hold. On returning to stage you palm duplicate ball from under your vest, and drop it on plate and palm first ball which you place under your vest. The ball now on the plate is composed of three handkerchiefs, the blue one being on the outside of the ball. Now take one of the cylinders from table and place on plate with ball; going to someone in audience, have them place ball in cylinder and hold the palms of their hands over each end of cylinder. Performer returns to the stage and picks up red handkerchief and slips it through loop of "pull," which until now has been over left thumb. Now you take up the cylinder and place handkerchief in it and, holding palms of hands over each end of cylinder, you command handkerchief to vanish, at the same time raise hand a little from end of cylinder on the side which pull is, in order to allow handkerchief to slip out easy, which is drawn up your sleeve by pull, as you extend your arms a little; place cylinder on table and walk to person holding the other cylinder and have them remove ball, which they unroll and find the three handkerchiefs all tied together; red, white and blue.



## ***The Chameleon Handkerchiefs***

Three silk handkerchiefs perfectly white, are given for examination; also a small sheet of paper, all of which is found to be free from deception. The paper is then rolled up in the form of a tube, the three handkerchiefs pushed in one at a time, a few "passes" and the paper is unrolled, when the handkerchiefs will be found to have changed to red, yellow and blue.

**Secret**--For this trick you have a tin tube 3 inches long 1-1/4 inch in diameter; also a piece of white paper 8 inches square, and six handkerchiefs; three white, one red, one yellow and one blue. The three white handkerchiefs are laying on your table, also the paper for cone. Under paper have the tube prepared as follows: Cover the tin tube with one end of the red handkerchief, and sew it nicely, so that when you take the red handkerchief out of the paper cone, the tube hangs behind the handkerchief. You tuck the red handkerchief into the tube first, then the yellow one, then the blue one, and all is ready.

To perform, show the three white handkerchiefs one at a time, to prove that they are unprepared; then lay them on your table and take up the paper. The three white handkerchiefs conceal the tube that was under paper. Show paper and roll into a cylinder, then take up a white handkerchief at same time the tube containing the colored handkerchiefs, which is not noticed by audience as it is concealed by white handkerchief. Get the tube into the paper cylinder behind white handkerchief, in the act of pushing in the white handkerchief. As it is pushed in, out comes the blue handkerchief.

Next push in second white handkerchief and out comes the yellow handkerchief, then push in the last white handkerchief and out comes the red handkerchief, allowing it to hang over the paper cylinder, then catch it near top of cylinder and pull it out, tube and three white handkerchiefs are drawn out as the tube is sewed to red handkerchief, lay it on table, no one suspecting the red handkerchief contains a tube and three white handkerchiefs, now open paper and show it empty.

Another method of loading tube into cylinder is as follows: Have

a fine wire loop attached to one end of tube, and concealing tube under vest at bosom, allowing loop to hang out. In the act of showing the paper (which you hold in both hands), catch thumb of left hand into loop, and as you start to convert paper into cylinder, secretly pull tube into same.

And still another method is to have the tube concealed on back of chair, and when you show white handkerchiefs throw them over back of chair, then show paper and make it into cylinder, taking up one of the white handkerchiefs you secretly take tube with it and push into cylinder, etc.

## ***New Postal Card Trick***

First take a postal card and prepare it with writing, then fold it twice, but before folding tear a square corner off, place the folded card in one of your vest pockets and the corner in the other. Now fold your card in the middle lengthwise once, and then fold in the middle crosswise once. When you wish to introduce the trick show committee a clean card, while they are looking at it palm your prepared card and corner, then take the card from committee, hold it up so audience can see it and tear off a corner as near the shape as you can to prepared one.

Now ask one of the committee to fold the card and while he is doing so give the prepared corner to one of the committee and get away with the clean corner, now take the folded card from the person and while showing it to audience exchange for the prepared card and place this in someone's hat with a lead pencil, then request spirits to write. After a few moments request party to take the card and see if there is any writing on it. Let him read messages and match corner to the one other party holds and it will, of course, be found to fit exactly.

## ***Card Nailed Between Boards***

Take 3 cards and blacken their backs. Now force a small tack through each card, so that point is out on back. Lay them on table with backs up. Take two ordinary boards; have them examined. Lay boards on table, the bottom one over the cards. Get hammer and nail and give to someone. Pick up boards (cards will stick to them) and place them together, so that cards come between and have them nailed. Force 3 cards similar to those between boards and proceed with trick.

## ***Demon Cards***

For this experiment you require two packs of playing cards, one an ordinary pack and the other a prepared pack as follows: Take an ordinary pack and clip a small piece off the end of each card. When all the cards are cut this way the pack will be a trifle shorter than an ordinary pack. Have this pack lying upon your table where it will not be noticed. Performer calls attention to the ordinary pack and hands it to any person and instructs him to go among the audience and have any amount of cards selected. Pack of cards are then returned to performer, who walks back to the table for the purpose of getting a glass tumbler and he secretly exchanges the prepared pack for the ordinary pack, these he places in the glass goblet and has any person go through audience and collect all the cards which were drawn, and shuffles the pack. Cards are then placed in performer's pocket and he at once produces all the cards drawn. All he has to do is to select the cards that are a trifle larger than the balance of the pack.

## **Pipe Trick**

Take clay pipe, fill up with wadding (cotton wadding) loosely and keep in place at mouth of bowl by a wire screen. Wet cotton with gasoline. Prepare soap water and make soap bubbles with pipe. Let float in air and light bubbles with candle, they will explode with a big flame.

## ***The Wa-Ha-Gi Billiard Ball***

Over the billiard ball fits a half shell of glass, under the cover of the handkerchief the solid ball is palmed away while the spectator holds the glass shell, which when dropped into the water turns over the remains invisible. The bottom of the glass is just large enough to receive the shell. To hide the edge of shell two stripes are etched on the glass.

## ***Magic Die, Flowers and Glass Box***

Have a three inch die and glass box made so you can place the die inside the box. Also have a handkerchief made by sewing two handkerchiefs together and stitching between the handkerchiefs five pieces of square cardboard which are the same size as die. The flowers are spring flowers same as used for paper cone, they are fastened on back of handkerchief with a thread. Thus prepared place die in handkerchief and taking hold of cardboard in handkerchief let die drop onto servante, and place handkerchief over box and make the motion as if trying to get the die in glass box, while doing so break the thread and the flowers will fill the box, remove handkerchief quickly and the die has vanished, and audience see flowers.



## ***Ice Freezing Extraordinary***

A square tin box is brought on the stage and placed on a skeleton frame, shown empty and where it remains during the entire experiment. It is then filled with water and covered with a thin cover. A candle is then placed under tin box, about the centre and remains there a few moments, then cover is removed and a large cake of ice, nearly filling the box, is taken from box. The ice may be either broken and previously borrowed articles found embedded in it, or ice for making lemonade (magically).

**Explanation--**Box is made on plan of Inexhaustible box, i.e. bottom double and works on hinges, show frame and set box on it, the box containing cake of ice. Tip box towards audience and thus show empty, tip towards shelf and show bottom solid, etc. Water runs down side of ice, through hollow legs, into bottom of frame. There are two holes in the real bottom for the water to pass through, these being near corners, over front legs, and are concealed by fingers when box is turned forward to show empty. Use faked pail having false bottom near top to show full of water. Ice cannot entirely fill box, as tin could not be tipped forward. Size ascertained by trial.

## ***New Programme, Ring and Envelopes Trick***

**Effect--**A ring is borrowed, also a programme, and the latter is torn in two. Volunteer is invited on the platform. Half of the programme is spread over the hand and the ring placed on it. The performer then squeezes up the programme and ring, and commands the programme to change into a series of envelopes, with the ring in the center one, and this is found to have been done. Volunteer has to open the four envelopes before he finds the ring. Performer now repeats the trick with the other half of the programme, and again the ring is found in the innermost envelope, and is returned by the volunteer to the owner. The broken envelopes are then taken in the hand, squeezed up, and transformed into programme again. "Very elaborate effect."

**Secret--**The ring is changed on wand (old dodge). The first series of envelopes is perfect (made out of similar programmes, of course) and carefully sealed up with dummy ring inside, concealed (say) in right pocket, and (when programme is handed) taken between root of thumb and finger--forefinger. The programme is laid on the hand, the substitute ring is placed thereon under the thumb, all squeezed up, and envelopes produced--the programme is slipped into pocket while the audience are gazing at the opening of the envelope. Lay great stress on the fact of each envelope being securely fastened, and ask the volunteer if he can take out the ring without breaking the seals, etc., etc. Meanwhile arrange for the repetition of the trick. The second series of envelopes is open at one end, and has a flat thin tube (a la shilling in ball of wool) down into "not quite" the bottom of the smallest one (the tube to fit loosely), and place each succeeding envelope was side downwards.

While the volunteer is working with the first set, drop the borrowed ring down the tube into the innermost envelope (say in the right pocket) shake the tube, withdraw it, then bend the ends of the envelopes over tightly, and proceed with the trick with the second half of the programme as before, asking the volunteer if he would like to do the trick.

A good finish is made by collecting all the envelopes, having a complete programme in the hand, and changing them for it. To

do this simply squeeze up the bundle, bring the programme to the top, and hand it over, immediately taking wand in hand.

## ***Bertram's Programme and Coin Trick***

The program at the hall you are performing at should be (for convenience) printed on special paper. Linen paper. Preparation for the trick: You must now get one of these programmes and cut it into four equal parts and make out of it 4 little envelopes so that they will go one into the other. Now borrow a marked quarter on a small plate and then get a gentleman on the stage to hold the plate and keep his eye on the quarter. Take up the quarter in your finger and call attention to the fact that the coin is not for one moment removed from their sight, but left in full view on the plate. Just as you are about to put it on the plate, ring the change and leave the substitute on plate and keep the marked one palmed. Now borrow a programme from any one and call your assistant to bring you a stick of sealing wax. When he comes on the stage and hands you the wax you put the marked quarter in his hand as you take the wax, and he at once goes off, places the coin in envelopes, one in the other, sealing them (sealing each one).

Performer now gives the programme to gentleman on stage telling him to wrap quarter in it. While he is doing this, the assistant places on table the envelopes and then walks off taking something with him. Performer now picks up wand from table and steps toward gentleman saying: "That is not the way to wrap it; take it out again," and the performer then spreads out the programme over his hand which contains the prepared packet. Now let gentleman place quarter on programme beneath thumb and crumple it up in hand at same time calling attention to the fact that you double it up with one hand ONLY and as you do so gradually work the parcel of packets up on the top of programme that you have just placed the coin in. Quickly get it to the tips of fingers and let gentleman hold it in his hand. You then take the sealing wax and strike the packet four times; then tell gentleman to unfold programme and to his surprise he finds an envelope sealed with wax, this he opens and finds another also sealed, then a third and a fourth, this fourth is given to the person of whom you borrowed the coin, and let him ascertain that it is the identical quarter he offered.

Now take the pieces of programme in one hand while with the

other you secretly palm a nicely folded programme then place the pieces on it quickly and squeeze them up into a ball in one hand. Work the programme to the top, then to the end of fingers, and let gentleman unfold programme, and while he does so get rid of the pieces. Show programme is restored and hand it back to the person it was borrowed from, and end.

## ***New Chair Mystery***

The performer is provided with a piece of black silk thread made stronger by black wax. One end is attached inside the left leg of his trousers and the other is attached inside his right leg of trousers. The loop thus made hangs down and touches the floor, but in a room well lighted the fine thread cannot be noticed. Performer takes the chair and after rubbing his hands over it, causes the leg to fall into the loop. He then backs away gently and the chair follows him, while he pretends to be throwing whole chunks of magnetism into it.

This is entirely new, being the invention of an European medium.

## ***How to Tell Numbers of Borrowed Watches***

All that is necessary for the performance of this trick is the knowledge of the number of one watch, which is supplied by confederate. The trick is now worked the same as in reading "envelopes." When the first watch is picked up he reads off the number of the inside of confederate's watch case. He now opens the watch case and reads off confederate's number and then notes the real number which he reads for the next watch. The audience are requested to note the numbers as read and when the watches are returned the owners state that the performer has been correct in his assertions.

## ***Slade's Wonderful Spirit Knots***

With this trick Slade very successfully duped the celebrated German Scientist, Prof. Zollner.

**Secret--**Have two cords of the same length and same kind, into which have your "victim" make three knots. In your sleeve you also have two similar cords without knots. The four ends of the last two cords extend as far as the ring you wear on middle finger of right hand, they are just pulled through under this. Take the knotted cords and place the four ends together, at the same time secretly pull out the four ends from under the ring and place them over the end of the first cords so that first ends are hidden by hand, while the spectator believes the visible ends to be the ones belonging to the knotted cords. Have these visible ends sealed to the table top or to a card, using if possible a stranger's seal, move hands towards the read and downwards, and the cords pull out of the sleeves. Take the knotted cords, bunch them up and get rid of them. In due time spectator finds that the knots have disappeared from the cords.

This experiment should be skillfully performed and proper mise-en-scene arranged for it, by reversing the process you can cause knots to appear on one or two cords that were apparently sealed to table minus knots. A table cloth pushed slightly towards the front of the table to make room for the sealing would more effectively hide the spiriting away of the first cord.



## ***Dexter's Sealed Cord Test***

Have board three by five feet with two staples in it, examined by audience or committee, board then placed against wall, a box height of chair and placed THREE INCHES FROM BOARD. The staples correspond to lady's neck, and about three inches above small of back.(?) Two gentlemen are chosen by audience to tie lady, first gentleman ties string around lady's neck through staple, good knot solid and secure. Next gentleman ties string around lady's wrist (right wrist) and passes string through staple to other gentleman. At the same time lady catches up a little slack of string and pushes her hand down behind her and blow the staple, gentleman then pushes lady's left hand back and ties the other end of string around her wrist, all ready, gentlemen leave the stage.

A plate is placed on lady's lap, glass of water placed on plate, curtain drawn in front of lady. Lady can reach and get glass and drink water, taps foot, curtain drawn back, audience sees glass empty, (also hears glass placed back on plate). Next, handkerchief is tied around lady's neck, (lady used one hand and teeth to tie knot), other tests, etc., etc.

Performer with a knife cuts string which is around lady's neck, lady bends forward and then cuts lower string close to hands and lets the piece of string drop behind the box. Lady steps forward and holds up hands to audience examine knots, etc.

Whoever named the above, "Dexter's Sealed Cord Test," know nothing whatever of Dexter, because he never used any such kind of a tying feat.

## ***Bellachini's Cabinet Mystery***

**Preparation**--Make a large sack of dark flannel, 7 feet long by 2-1/2 feet wide. Cut two small holes two inches apart at back of sack, and as high as your wrists when standing in sack. Have four pieces of tape, two pieces one and a half feet long and two pieces one and a quarter long.

Commence by asking two persons to step upon the stage and allow them to examine the sack, have the two small pieces of tape in your pocket where you can get at them quickly. Next show the large pieces of tape and request the persons to tie a piece around each wrist and seal the knots. You now get into the sack and while getting in you must manage to get the tape out of your pocket and stick them through the holes in sack, and have them tied and sealed. It will now appear as if your hands were secured.

Pieces of tape are tied. Now you get in to cabinet and have curtain closed, and you can ring bells and blow horns, etc., etc. Then curtain is opened and knots examined. Now ask one of the committee to step in the cabinet, have his eyes blindfolded, curtain closed, then you turn his coat inside out, take off his collar, etc., and then get back into position and have curtain opened; this makes a laugh.

When ready to finish your act have knots examined, etc. After the person has untied the tape quickly pull them in and put them in your pocket and pull out hands, showing wrists as tied as first.

Whoever named this act, knew nothing about Bellachini or his work. He never did anything in this line.

## ***The Three Knotted Charmed Handkerchiefs***

Can be introduced into either light or dark seances or where hands say are handcuffed behind back, or any similar manifestation. First method: Is to borrow three handkerchiefs, have them tied up, or your assistant pulls the knots into the required slip knot, (the old knotted handkerchief "fake") and a simple pull with them of course separates them. He simply hangs them on top of screen or in front of you, or cabinet in which you are manifesting, or he can throw them over to you, in either case you pull them apart. Tie one around each arm at elbow and third around head, slip hands into bonds again as you call for cabinet to be opened.

**Second Method:** Is to use your own handkerchiefs of which you have duplicates, the moment you receive the knotted ones which in this form may be knotted up in all sorts of form or ways by audience, or better still while assistant is making an observation. Before handkerchiefs are thrown into cabinet you free yourself and tie duplicates in the required position, and when you receive the knotted ones pop them into pocket, slip into bonds and have cabinet opened as you do so.

## ***The Eglinton Rope Test***

An excellent rope tie, much used in England. Performer comes out with a piece of rope which he has someone tie around his wrist very tight, knots sealed, end of rope tied to chair back and sealed. Use cabinet or canopy, doors closed and tests occur.

Medium has a blade of knife sewed at back of trousers and cuts the cord right through and produces from his pocket another rope similar to the first one, "faked" as follows: have a piece of rope same length as the one in hand when coming before the audience, tie two single knots about three or four inches apart which will be two inches from the centre. Have these knots sealed with wax. Now tie a double knot on rope, tying ends together and have this knot about one inch or so on each side from the single knots. Have sealing wax on this knot also.

Performer takes particular notice how the first rope on his wrists is sealed and so he seals the knots, while the lecture is going on and can be done quickly. Medium then puts ends through back of chair and fastens rope as the first one was fastened then sits down in chair, thrusts his hands through the large loop, gives his hand a twist around so that the two single knots meet between the two wrists and these two knots being sealed separate appear as one, when wrists are together, and the two knots appear as one good knot.

Lights up, inspection follows and medium found securely tied. Conceal first rope, gentleman from audience cuts the rope to show all tied, or release yourself and disappear from back of canopy.

This is also mis-named; Eglinton, the medium, did not use rope tying feats.

## ***One of the Davenport Rope Ties***

Use a common wooden bottom chair with two holes at back of seat. Rope used is about two yards long, and tied around one wrist up as far as possible, both hands then placed behind back and wrists tied together, performer holding his arms as straight as possible, so that the rope is tied well up on wrists; then performer steps into cabinet and ends of rope are pushed through holes in chair and secured, door closed and work commences.

The cord being well tied up the performer's wrist, by slacking the hands he can easily squeeze out the knots. From position behind it is impossible to tie hands so that one cannot be gotten out. Once out he slackens the other knot and hand slips out.

When manifestations are through he appears with rope in his hands and says he will be found tied up as the audience tied him in the space of one-half minute. While talking he folds rope up in hands and at the moment door is closed he changes it for another concealed rope of same kind tied in a double bow knot, loops being in the centre. By pulling ends, loops become smaller and tighter on wrists; he ties ends under chair, slips hands through loops giving one a full turn around and holding arms and hands as at first, he appears similarly bound. Inspection follows.

## ***Braid and Tape Test***

Take a piece of tape about two feet in your hand and call up two gentlemen out of audience to tie you up; after they come up you go into cabinet and sit down on the chair, which is a common spindle chair with the spindles running up the back, so when you sit down on chair give them the tape to tie around your wrist, they will tie it the same as vanishing knots. After they have tied one wrist you ask them what kind of a knot is this, at the same time pulling on one end of the tape thereby converting it into a slip knot. Next you put your hands behind your back and at the same time run the other end through the back of chair, and let them tie it to the other wrist, expanding it as much as possible, for it gives you more room to work the knots back. You should always have two or three pieces of tape in your pocket tied with a slip knot, for if they should tie you too tight, you could break the tape and put it in your pocket and place one of the other tapes on your hands. Then perform your tricks such as ring bell, showing your hands through hole in cabinet, etc., etc.

### ***The Medium's Ties, Similar to No. 23***

Use street car cord and allow knots to be pulled very tight, which cannot be enough to give pain. Have your left wrist tied tightly, knot sealed and hands placed behind back and in placing the hands behind, the little finger reaches out on arm catching hold of rope and twisting it once. The right hand is then laid on left so that back of right wrist rests on front of left arm. Rope is then tied to right wrist, ends of cord are passed through hole of chair and tied.

As soon as cabinet is closed performer gives his right hand a half turn which releases it, tests occur. Performer wets his hand with his tongue, puts it back in rope, gives the necessary twist and he is tied again as tight as before. With a little practice it can be done very quickly.

## ***New Spirit Post***

A piece of two by four scantling is brought upon the stage and a hole bored through it by a member of the committee at a spot where the auger has been started by performer. The scantling which is about four feet high is then nailed to the floor. Performer sits with his back to the scantling and his hands behind him. Two ropers are handed to the committee and they are instructed to tie each rope around each wrist of the performer. All knots are sealed and strips of court plaster are pasted around the rope, and they are drawn through the hole in scantling and a big knot tied to them at the back. Strips of court plaster are pasted around the knot and joined to the wood so that it cannot be moved. A spike is then procured and driven into the scantling. Two guy ropes are then tied around the spike and these are used to brace the scantling and keep it firm. A sheet is placed over performer and hands appear through openings. They ring bells and write messages to people in audience. The committee pulls sheet away and performer is found to be bound as at first. The court plaster strips are still around knot.

A large (dry goods) box is placed over him and he does a few more wonders. All of a sudden he rises and yells, "Take it off," "Take it off," and they remove the box and find him free. The rope has been cut from him although in his position it would be impossible for him to do it himself.

Explanation--The scantling has had a piece taken out of it near the top, into which the bit, or blade of a carpenter's plane is inserted. The hole for the rope is cut a fraction of an inch beneath the blade. The plug which was taken out to make room for the plane blade is fitted back on top. When the committee man drives the heavy railroad spike into the scantling it forces the plane blade down through the rope and the performer's hands are free and all work takes place.



## ***New Spirit Hand***

This is for a private sitting with one man in cabinet or dark room. The victim and the medium sit opposite each other at a round table. The medium says, "Place your feet on my toes, sir, now you could feel my feet if I should move?" The victim says: "He can;" but he cannot. The medium's foot is quietly slipped out of a very neat imitation of the toe of a shoe made of steel and is held down by the victim's foot. While the medium is asking a few questions, a rubber hand is pulled from the trouser leg and adjusted by a fairly long piece of steel upon the right foot. The operation requires but half a minute, and then the medium says: "Now sir, place your hands upon mine, if I was to move you would know it?" Spirit hand now appears and disappears, it will tap a tambourine hanging over victim's head and will slap him in the face, etc. Finally the medium releases the victim's hands, rises and with a piece of rubber used for the purpose draws the hand back to his leg with a snap.

The seance is over and the man believes.

## **The Mystery of L'Hassa**

**Effect--**Performer comes forward and, picking up two trestles which are now on the stage, he walks to foot lights to show that the trestles are unprepared; he places the trestles in center of stage about six feet apart. Next he places a board on the trestles and introduces a young lady, and after making some hypnotic passes over her, picks her up and places her on the board on trestles. He now removes the two trestles from under board and, to the astonishment of the audience, the board with lady on it is seen floating in space.

**Secret--**There is a curtain hanging at back of stage, it is of a striped pattern, lines running up and down (dark lines on light back ground). The two trestles we will call No.1 and No.2. Pick up No.2 first, swing it around, then do the same with No.1; then place them in center of stage, (well back), just far enough apart to allow board to rest on them. No.1 trestle is unprepared, but No.2 has a wire fastened to it. The end of wire is made into a loop and this loop goes around two nails, one on each end of trestle. The wire does not show as the back ground conceals it, as it is a striped pattern. The end of wire goes to top of stage.

Now show the board (which is a foot and a half longer than the lady used in the illusion), and lay it across the trestles, getting end in loop of wire on trestle, take a long stick and wave it all around, over and under board, but you must guard against hitting wire on end of board. Now introduce the lady and, apparently hypnotize her, then pick her up in your arms and lay her on the board, (feet towards trestle No.2). Assistant now brings in a leather pillow from side of stage to which is fastened second wire, running to top of stage; the pillow is placed under the lady's head, at the same time get wire under the board. Now remove trestle No.1, then trestle No.2, and lady lays floating in space on the board and front curtain is dropped.

An improvement can be made on the above by having the board drop to the floor when you remove trestles. In order to do this it is necessary for the lady to wear a sheet-iron band over her shoulders under dress; also a sheet-iron band around the calf of each leg, under stockings. These iron bands are to protect the

lady from being cut by wires, as one in this method is placed around lady's shoulders, when placing pillow under her head, and the other wire is placed under her legs when placing her on the board. Lady must make herself very stiff, so that when trestles and board are removed she will lay straight in space.

## ***New Spirit Pictures***

**Effect**--Medium shows a wooden frame, on which is a piece of cloth, both sides of which are shown and this is placed on an easel. A lamp is then placed behind cloth thus rendering it transparent, and impossible for anyone to touch cloth from behind without being seen. Lights are then lowered a trifle, a little music, and a spirit picture is slowly precipitated upon the cloth in colors, this being visible to every one present.

**Secret**--For this experiment procure the following ingredients from some druggist: "Sulphate of Iron," for blue; "Nitrate Bismuth," for yellow; "Sulphate Copper," for brown; make solutions separately for each, by dissolving a small quantity of each ingredient in warm water. Now make a solution of "Prussiate of Potash," and put it in a bottle Atomizer. Now with a brush for each color, make a picture, landscape, portrait or anything you desire, on a screen of unbleached muslin, when dry these are invisible. Show the screen and set it on an easel in front of cabinet, now slightly dampen muslin and place a lamp back of it on a chair, lower lights a trifle: your assistant or medium in cabinet takes the atomizer, and from behind sprays all over the back of screen with the solution of prussiate potash, which slowly brings colors out.

Effect is weird, and, although, perhaps not artistic, it is a novelty and is apparently done by unseen agency. Light being placed at back of screen, audience can see that no one approaches screen. A little music covers sound of atomizer. Always see that the atomizer is screwed up air tight before using it.

## ***Shrine of Koomra Sami***

**Effect--**A large cage containing a small one is seen on stage. A person is placed in small cage, when he instantly multiplies into three distinct beings, i.e., his double, his astral being and himself.

**Secret--**The large cage is six foot high and three and one-half foot square, standing on four small legs with castors. Small cage is in centre of large cage, and is twenty inches square and same height as large cage. Both cages have bars on all sides running from bottom to top. The large cage has red curtains in front and on both sides, all work on spring rollers. The background of stage is dark green, and the large cage has a curtain at back of same material; behind this curtain are concealed gentleman and lady.

When performer places the man in small cage, he pulls down red curtains in front and sides of large cage, gentleman and lady now let green curtain at back fly up, move two or three bars aside, and step into cage replacing bars. (This must be done quickly). Performer quickly lets red curtains fly up, opens door of cage, and out step the three persons.

If you wish you can have green curtain on back of cage painted with black stripes to represent the bars of cage, in this case you do away with bars at back of large cage, but you cannot turn cage around after trick, as you can do by using bars.

## ***Mysterious Cabinet of the Mahatmas or Wonder of Wonders***

On the stage is seen a small round cabinet resting on a high pedestal. Performer comes forward and invites a committee from the audience to come up on the stage and examine the cabinet; when they have finished the examination of the cabinet they take seats all around it, and the performer closes cabinet door and also takes a seat with the committee and commands the spirits to open the cabinet door; instantly it opens and manifestations take place. Then the performer asks the spirits to turn the cabinet around so audience can see on all sides, as well as committee; instantly cabinet revolves around without any one going near it. Musical instruments are placed in cabinet and are played; a glass of water placed in cabinet disappears; an empty basket placed in cabinet is filled with natural flowers; faces, hands and spirit forms are seen in cabinet, in fact here is no end to the number of tests that can take place in this cabinet and without a person going near it.

Secret--The cabinet part is what is commonly called the cheese box, it is the same shape only larger. Cabinet is placed on a pedestal. There are two mirrors occupying about a quarter of cabinet. These mirrors meet at the center post, and sides of cabinet being reflected in these mirrors, audience thinks they see all of cabinet.

Person who produces manifestations is seated behind these two mirrors.

## ***Spirit Circle Under Test Conditions***

On a board the size of a table eyelets are carefully arranged at measured distances apart and in such a manner that there are two for each sitter whether lady or gentleman, one for the right hand and one for the left. Beginning at any point in the circle a piece of copper wire is passed around the arm of the first sitter through the eyelet in the board, around the other wrist through the other eyelet and so on to the next sitter. In this manner the wire is threaded through and through, fastening each person to the board and to the neighbour on either side, in fact to the entire circle. The company, including the medium being interlaced, the ends of the wire are tied together, the joint covered first with paper, then with wax and are sewed and tied as desired and any seal is set on. Now the lights are extinguished and the usual manifestations take place.

Secret--The medium has on false shirt sleeves so all he has to do is to slip out his arms as soon as the lights are extinguished, then go through the various manifestations, replace his arms in the sleeves and call for lights. Now all can be examined and of course is found O.K. Then have some one cut the wire.

## ***Great Mahatma Miracles***

This is an ordinary cloth cabinet, but there is a platform four feet square. Lady sits on chair and manifestations occur whilst her wrists are secured with ribbons, and audience see her hands extending from the sides of cabinet. The front of cabinet is made with a piece of round or oval shaped gauze in centre, this is to allow audience to see her all the time.

Secret--The two front legs of cabinet are hollow. Performer asks audience for bunch of keys, bells ring, and keys are brought from front of house. They place newspaper inside with scissors, and beautiful designs are cut out. There are a thousand tricks that can be done. Traps in hollow front legs are hidden by tape running along on floor of cabinet. At the bottom of trap there is a very strong rope, and when cabinet is examined, assistant below holds rope very tight so no one can open it. Of course all the "miracles" are worked from under the stage by assistant.



## ***One Way of Producing Great Mahatma Miracles***

The medium has a boy with her about 7 years of age and quite small. He crouches under her skirts and comes on with her, and is not noticed. She enters the cabinet and passes her hands through openings in the sides of the cabinet and her hands are held by a committee and all the usual cabinet work goes on, the boy rings the bells, plays musical instruments, etc., etc.

The cabinet is made of some black material and the transparent gauze is of some light color. The boy is dressed all in black, a la Black Art.

The originator of this wonderful idea should receive a leather medal for his inventive genius!!!

## ***One Method of Materialization and Dematerialization***

The test is done by using white silk used to sift gunpowder.

One yard of this silk can be carried in an ordinary thimble, and five yards may be carried in a watch case. A face made of rubber, painted with luminous paint. It is blown up the same as a toy balloon but retains the shape of a face. The whole affair is concealed in a half inch gas pipe running on the stage under the flooring. Assistant works the bellows from behind the scenes. The spirit, (rubber face and silk sack) rises forced up out of the gas pipe end by the air pumped into the silk sack.

## ***Kellar's New Karmos***

**Effect**--On the stage is seen a platform with four feet. On this stands an ordinary looking chair. The lady sits down on the chair facing the audience, and is securely blindfolded by the performer, who then makes some magnetic passes over her.

He then passes an unprepared pack of cards out for examination and has them shuffled. Going back to the stage, he stands behind a small table, and, holding the cards so that their face is turned toward the audience, he draws off one card after the other and throws it on the table, the lady naming each card as soon as it becomes visible.

For the next test he borrows a banknote and with it walks to a blackboard on the stage; the lady dictates to him the value and the number of the banknote, he writing it down on the blackboard. He also borrows a check and the lady states at what bank it is payable, who made out the check, who is its owner, what the amount is, etc.

A spectator next chooses a word out of an unabridged dictionary and asks the lady what the word is and she instantly tells him and describes the word.

Another spectator writes a couple of numbers on the blackboard, brought down in the audience by the performer; the lady instantly squares and even cubes the number.

For the final test some one writes four rows of figures on the blackboard, each row containing four figures. The lady audibly adds the numbers and dictates the result to the performer, who then carries the blackboard away to the front of the stage and she now adds the rows in any manner desired, that is, from right to left, up and down, etc. She also mentions any number struck out or touched by the performer.

The secret of this seemingly remarkable performance is a very simple one. Everything that the performer does is seen by an assistant behind the scenes, who tells the lady what to say by means of an invisible speaking tube, which consists of a rubber

hose, passing from behind the wings, underneath the floor up to the platform, the rear leg of which is hollow. There is a small opening here on which the rear leg of the chair, which is also hollow, rests.

The chair used is a cane seat one, of the kind known as "Vienna Bent Wood" Chairs. The rear leg of chair is hollow, also part of the seat of chair, also spindle in back of chair where connection is made. The lady who enters from the rear does not show the back of her dress, on which is fastened another tube, leading up to her ear and hidden by her hair, which hangs down loosely.

Under cover of making passes over her the performer connects the tube on her back with the crosspiece in back of chair, thus completing the connection. Anything spoken by the assistant into his end of the tube, which has a mouthpiece there, is heard distinctly by the lady. The rest is easy. The assistant sees the faces of the playing cards and tells them to the lady who calls them off. The performer holds the banknote in such a manner against the blackboard, which is turned slightly sideways, that the assistant can read its number and value by means of a spy glass, Same with the check.

In the dictionary test, the performer requests the gentleman to ask the lady what the 10th word on the 35th page is. The assistant who has a duplicate dictionary, hears this, looks the word up and tells it to the lady. The squaring and cubing of two figures is done by means of assistant referring to a table of numbers, already squared and cubed before the trick, the table including all numbers from 1 to 100.

The adding of four rows of figures will be easily understood now. Meanwhile the assistant copies the four rows and the performer now moves the blackboard to the front of the stage, thus bringing it out of the assistant's range of vision; but as the assistant has copied the figures, he can tell the lady what the result of adding the first row comes to and any other question pertaining to the figures.

The trick of the lady telling any figure touched by the performer is one of prearrangement, the lady and performer having learnt by heart a number of figures, which are touched and called off by the lady in their regular order. The performer then makes some more passes over the lady, under cover of which he disconnects the speaking tube and then removes the blindfold from her eyes. She bows and leaves the stage but does not show her back.

## ***Silent Thought Transference***

A lady (or gentleman) while blindfolded tells the suit and Value of any number of selected cards, solves arithmetical problems, gives numbers of borrowed bank notes, tells time by any watch, describes borrowed coins, gives proper names as selected, and many other tests. All this is done in absolute silence and while the lady is unable to see, and can be entirely surrounded by any committee.

In this feat of Silent Transmission of Thought, there is used what is known as a Silent Code.

The principles and details of this Code are easily acquired and are so fully described in the following that they may be readily understood. There being no elaborate code to learn it will be seen that this method does not require as much application and practice as systems in which certain codes and signals have to be memorized.

By means of this code all the usual effects generally exhibited at Thought Beading Seances, can be reproduced. The medium is completely blindfolded and if necessary can be surrounded by a committee from the audience, to see that the medium is not connected with the performer in any way and that he does not make any queries of the medium or signal to her. Performer need not change his position at all.

It consists in both medium and performer counting mentally and together. It is a known fact, that the beats for "common time" are always the same in music, therefore with little practice it is easy for two persons starting on a given signal to count at the same time and rate, and when another signal is given to stop, and of course they will both have arrived at the same number. This then is the actual method employed in this code and from it you will see that any number from 0 to 9 can be transmitted by the performer to the medium; which of course is all that is required.

It is best to experiment and find out what rate of counting best suits the two persons employing this code, but the following

suggestions are offered: It may perhaps be best to commence counting at a slow rate; then gradually increase; until you find advisable to go no quicker, and then adhere to one rate and always keep it.

Say you have in the room when first practising, a loud ticking clock, with a fairly slow beat, on the given beat or signal you both start counting at the same rate as the clock, of course the clock must be removed when the rate has been well learned; or count at the rate of "common time," viz.: 1 and 2 and 3 and 4 and so on, or practice with a "Metronome," such as is used during piano practice for the purpose of setting time and is of course made adjustable.

A very good rate to finally adopt is about 70 to 75 per minute. Whatever rate is found to suit best must be adhered to, you will find at the rate mentioned any number up to 9 can be transmitted with absolute certainty, after an hour or so of practice.

Now that the principle has been explained, the next items are the signals to be transmitted to give the medium the cue when to start, and when to stop, counting mentally.

**Coin test--**Say the performer has borrowed a coin the date of which is 1862, the first figure of the coin 1 and 8 are generally understood as most coins in use are 18 something or other, if of date 18 in the hundreds, then the performer must advise the medium of this by means of a wording of reply to the person who lent the coin, which can easily be arranged to suit one's fancy. The 6 and 2 have therefore to be transmitted.

The performer stands away from medium or amongst audience. The medium being on the stage securely blindfolded, performer takes his Position with chalk in hand in front of blackboard, holding coin in other hand. He does not speak a word but simply looks at coin, after a pause, the medium calls out: "The first figure I picture is a one," or words to that effect, now immediately the lady stops speaking they both commence to count mentally at the rate agreed upon by practice. In this case the number to be transmitted is 6; as the last word of sentence is spoken they commence mentally 1-2-3-4-5-6; during this short period the performer glances down at the coin as if to verify what the lady has called out, as soon as they reach the figure "6" the signal "Stop" has to be transmitted. This is done by the performer putting down on the blackboard sharply the figure called out by the lady, viz.: "One" (1).

It will be seen by this method that the signal is quite easy to transmit and it is perfectly natural to put down the figure on the board quickly and sharply. The third figure of the coin is now known to the medium, the last figure "2" is transmitted in the same manner as the previous figure, the lady says the second figure I see is "8," as soon as she ceases speaking they commence the counting again 1-2, on the arrival at the figure "2" the performer puts down the "8," previously called out, sharply on the board, which is the signal for "stop," the lady now knows the full date of the coin.

The metal of the coin must be indicated to the medium previously by the wording of the reply to the owner of the coin after it has been handed to the performer, which can easily be arranged to fancy, the value of the coin or its equivalent number in the same way as the previous figure and between the "6" and "2," that is, after the lady has called out the "6" they commence to count for the value, when an "0" occurs in the date, no pause is made, the performer putting down the figure on the board for the "stop" signal immediately the lady stops speaking, this if followed carefully will be found quite easy and natural in practice.

Any other system that one may adopt for giving the starting and stopping signal can of course be applied, but the method here proposed will be found to answer the purpose, and cannot be detected.

The performer states to the audience that the lady will now tell the value and number of a borrowed banknote. He also states that the lady does not see the numbers on the note in the right order and that he will therefore make divisions on the blackboard for these numbers, supposing she sees a "3" first she would cry out "I see a 3" and it belongs in the second place and so on, till the full number has been called off.

Performer also states that she will first call off the value of the note. Performer now borrows a banknote remarking that he usually returns it. We will suppose he is handed a \$5 bill numbered 00481, he takes it back to the stage and on the way there he looks at its value, when the lady hears that he has returned she raises her hand to her head as if in thought. At the moment her hand starts to move, both count 1-2-5-10-20-50-100 and so on, at the third beat, viz.: "5" performer gives a sigh, the lady then waits a moment and says it is a \$5 bill. While she did this performer has looked at the third figure of the note, as it is understood between them that

she should first call out the third figure of the note, which in our case is "4."

It should have been mentioned before that in the banknote test the following order must be learned by both performers previous to performance: 1-4-5-3-2 so that now the lady has got to the \$5 as mentioned above, begin to count 1-4 in second time, on the second beat, viz.: "4" performer will stop lady from counting any further by slowly writing down \$5 lady knows now that, the next number is "4" she however waits a moment and then exclaims, "I see a 4 and it occupies the third place."

As soon as the word "place" is said both again begin to count. Now the figure in the first place is to be called off next according to the pre-arranged order. This order is supposed to be 3d, 1st, 9d, 4th, 5th, 6th, and so on. Of course any other order will do as long as both know it beforehand. Now "0" is the same as "10" for the test, for when a number is not in the formula 1-4-5-3-9 you must take the number to which when 5 is added to it makes the number you desire, for instance, for 7 take 9 plus 5 equal 7, for 6 take 1 plus 5 equal 6, 5 plus 5 equal 10.

So the third beat will be the one on which the performer will write down the "4" just called out. So immediately the lady has said "place" both count 1-4-5 and on the "5" the performer will write down rather quickly in the third place a "4" immediately the "4" is put down the lady knows that the next number according to the above arrangement which occupies the first place must be an "0," but she allows a second or two to elapse before calling it out, by this giving time to look at note for next figure.

By putting down a previous number rapidly the lady knows that she has to add 5 to the number just communicated to her, which occupies the second place, and so that he is ready to begin counting immediately she has finished her sentence, then she calls out: "I see an "0" and it occupies the first place," immediately she says, "place" both count for the "0" in second place, 1-4-5 on the 5 performer rather quickly writes down "0" in the first place, after a moment or so the lady says, "I see another "0" and it occupies the second place."

Immediately on the word "place" both count for the "8" 1-4-5-8, on the beat for "3" the Performer rather quickly, by this communicating to her that she has to add 5 to the transmitted number "3," writes down an "0" in the second place, then after a second or so the lady exclaims, "the next figure I see is an "8"



and it occupies the fourth place. At the word "place" the performer deliberately writes down an "8" in the fourth place and the lady calls out, "I see a 1 and it occupies the fifth place."

She would go on counting to herself as she would not know whether there were more figures or not, but the performer would next refer to the number being all right and she would know it was all over. \$5.00 "00481."

**For black-board work:** The performer asks any member of the audience to put down upon the board 4 or 5 rows of figures, usually composed of about 5 figures in each row. While this is being done, the performer informs the audience that he shall transmit the total of the columns of the figures now being put down to the medium.

The sum having been put down on the board say something like this:

**7234**  
**8679**  
**3201**  
**3795**  
**6423**

the performer adds up first row quickly so as to arrive at first total of unit column, this, you will see, amounts to 22. He has however, only to transmit the 2 as amount to be carried is not necessary to be known to the medium.

He therefore now takes the chalk in his hand and says audibly to the person who has put down the figures, "thank you," the lady who has been listening for the signal as soon as the performer ceases speaking they commence the mental counting to the transmission of the 2, viz., 1-2.

**7234**  
**8679**  
**3201**  
**3795**  
**6423**

---

**2933**  
**2**

Immediately on the repetition of the word "2" the performer draws a second line under the column of figures on the board,

the sharp tap of the chalk on the board at the commencement of the action of drawing the line, indicating to the lady to cease counting and call out the figure she had mentioned to herself when she heard the tap on the board, which she does, saying: put down under the unit column the figure "2."

The performer glances at the column as if to verify what the lady has called out, but in reality to allow time to transmit the total of the second column, which he has added up during the time the lady was speaking, not forgetting to add on "2" carried from the first column. In this case it amounts to 23. The 3 has therefore to be transmitted.

As soon as the lady ceases speaking, viz., on the word two, as above, they commence counting for the second column in this case 3, they count 1-2-3. The performer then puts down sharply on the board "2" first called out by the lady which is the cue to stop and then the lady knows that the second figure is "3" and calls out accordingly.

You proceed in this way until all the columns have been added.

This test is usually concluded by the performer pointing in quick succession to any figure on the board, which the lady calls out. This is simply an addition and is a pre-arranged order of certain numbers which the performer picks out as it were hap-hazard, but really in the order arranged beforehand. What we mean by pre-arranged order is to commit to memory a set of figures; at the conclusion of the foregoing test the performer points to 4 then 8 then 9 then to 1 and so on, medium calling out figures as soon as performer crosses it out with chalk.

**Card Test**--Have your cards memorized by their numbers: Ace 2-3-4-5-6-7-8-9-10, Jack 11, Queen 12, King 13, ask some one to select 7 or 8 cards. To illustrate the method, we will suppose he selects two of hearts, three of diamonds, five of hearts, seven of clubs, eight of spades, ten of hearts, ten of clubs, Queen of Diamonds, King of Diamonds, (nine cards in all).

Let him lay them in a row on edge of table (the edge furthest from you). While he does this take a look at them and notice which is the lowest card, convey the denomination (or value) of the card according to the following rule: Value is given by *laying down the card last named*. Count from the time last words leave lady's lips until the time the card is laid on the table, the number counted *to be added to the value of the card last named*, and if the sum is over 13 deduct 13 from it.

Suit is given by the manner of picking up the next card. Clubs, pick card up sharply and quickly giving it a kind of turn on table which will make an audible "scratch." Diamonds, draw the card slowly over the table towards yourself before picking it up. Hearts, make a thump when going to pick up the card. Spades, make the thump as if hearts but follow it by the scratch as in clubs.

The value of the first card cannot of course be given by laying down the last card named, nor can we count from the time the last word leaves the lady's lips, as she has not yet said anything. You say "thanks" to the person who selects the cards and then you both start counting; at the figure to be indicated make a "sigh." Thus in our example above the lowest card is two of hearts, say "thanks" and count 1-2. At two heave a "sigh" or better still "breath hard," the hearts you indicated by picking up the card with a thump.

Lady knows the first card, she names it and as soon as the last word leaves her lips count again. Now the next card in value is 3 of diamonds, but we will skip this and go to the 5 of hearts. You do not count 5 but only 3 (the last card named being 2 of hearts,  $2 + 3 = 5$ ). The heart is again indicated by a thump.

Skip the 7 of clubs and go to the 8 of spades, the lady says 5 of hearts and you both count at 3 lay the card down with an audible rap. Lady adds 3 to 5 and knows the next card is an "8." The spade is given by the thump and scratch.

Then you can give the 10 of hearts by adding 9, then the Queen of Diamonds by adding 2, the King by adding 1. Now you have skipped the 3 of diamonds, 7 of clubs and 10 of clubs. This was done so that the audience may not notice that the cards are given from low to high. You count 3 from the King (King = 13, plus 3, but according to rule you deduce 13 leaving only the 3). For example if the last card had been a Jack and you wish to give a "2," you count 4 (Jack plus 4 = 15 minus 13 = 2).

After giving the "2," you give the 7 of clubs by counting, of course always indicating the suit by picking up the card; all the "thump," "scratches" and "draws" are really natural moves as motions should not be made unnatural by making them too pronounced, the practised ear can easily tell them apart.

**Chess Knights Tour.** Patter--"We will now introduce what is known as the chess knights tour; for the benefit of those who are not chess players let me say that the knight is the little

figure with the horse's head and it has the most peculiar moves of any figure used in any game of that class, it can go around the corner.

The knight moves by starting from the field upon which he stands and going two fields or squares straight in any direction and then turning the corner and going one more field in some other direction. To illustrate (go to your blackboard and point it out) if standing on, say, field 20 he could get to 35, (show it) to 37, (show it) to 80, to 14, to 5, to 3, to 10, or to 26, a choice of eight fields, providing he stood on a centre field.

Now on account of this almost incalculable move it has puzzled mathematicians for nearly 9,000 years (chess is an old game) to know if that knight could be started here point to it) on field No. 1, and could be successfully led from field to field and yet never resting twice on the same field.

After centuries of calculations this has been solved by a Frenchman and we will solve it again tonight for you, but we will make it just 64 times as difficult by not commencing on No. 1, as scientists always do, but on any field you may designate. Common sense will tell you that the knight's trip must differ in each and every case according to his starting point and we propose to make it a great deal more difficult by having the moves calculated out by our medium, who you are well aware is totally "blindfolded."

A number being called out by one of the audience you mark it out, the lady calls off the numbers and you connect the lines and mark out the field; at the conclusion your black-board will show lines running over it, stopping once on each square, but not touching any square twice.

Explanation. The secret lies in this, that you return to your starting point, if you learn by heart the following:  
(1)-18-33-50-60-54-64-47-32-15-5-20-3-9-26-41-58-52-62-56-39-24-7-22-37-43-28-13-30-45-35-29-46-36-21-38-44-27-42-57-51-61-55-40-23-8-14-4-10-25-19-34-49-59-53-63-48-31-16-6-12-2-17-11-(1.) You see it begins and ends with or at One. This rotation is all you need learn.

Suppose your audience gives 12 as a starting point, you say: 12-2-17-11-1-18-33-50-60 and so on finishing with 16-6.

## ***New Silent Second Sight and Bank Note Test***

The trick is performed as follows: The lady is blindfolded and seated in a chair with her back to the audience. She holds in her hand a slate or writes on a blackboard, just as you please. You then in the middle of the audience say that you will convey to her any date or number of words, etc., without sign or signal. The lady is breathing gently and regularly, but so that you can see her and notice the heaving of her breast or shoulders. You then start her counting by drawing a deeper breath than usual yourself. You watch her breathing and she counts her breaths and so do you and you stop her when she has breathed up to the number you want by again giving another deep breath.

Let us suppose we want the number 74. You begin; the lady is breathing regularly and you give a deep breath to start her so that as you ask for perfect silence she can hear you, and as soon as she has heard your breath she begins to count her own from the very next breath and when she has breathed up to the seventh breath you again give another deep breath, (just long enough for her to hear you) which tells her that the number is 7, and she goes on counting from that seventh breath and you again stop her on the fourth breath, when she at once writes down on the slate or blackboard "74."

This is the principle on which the trick is worked. You will then understand that you can convey any figure, card or letter by the code. You do this in a drawing room or even in a hall if you can get your audience to be silent. But where she cannot hear you from any long distance, you have someone behind the screen or curtain to start her by making some little noise with the mouth, or anything else your fancy may suggest, but this person need not have the least idea of how the trick is done and any child would do for that. All the child has to do is to make a little hum or noise each time he or she sees the operator look at the article which he (performer) holds in his hand. This noise is to start and stop the lady when necessary and takes the place of the deep breath.

The operator must remain perfectly still and not make any sign or sound but merely look at the article he holds in his hand each time he wants the little child to make the noise, as the child or whoever is behind looks through a small hole and can see the

operator and is near the lady.

Thus, say you want to convey the Queen of Hearts. You look at the card or paper on which the name is written and immediately the child sees you look, makes the noise agreed upon. You then count the breaths up to twelve, when you look at the card again and immediately the child sees you look at it again, makes the sound. You then count the breaths up to three and then look at the card once more, which stops the lady, She then knows that the card is to be written down. The Queen of Hearts is conveyed by fifteen breaths, twelve for Queen and three for suit.

Of course you see that you can convey anything if you only arrange a code with a number for each article. You must practice it when alone for a time with your subject or assistant and you will soon learn it.

Dates of coins you only need convey as a rule the two last figures, as nearly all coins are Of this century. Numbers of bank notes, tickets or watches. Any card from a pack, count the Ace as one and when you get the Jack count it as eleven, Queen twelve and King thirteen. The suit will follow next by remembering that the Club is 1, Diamond 2, Heart 3 and Spade 4. Words by the following table:

1	2	3	4	5	6	7	8	9	
1--	A	B	C	D	E	F	G	H	I
2--	J	K	L	M	N	O	P	Q	R
3--	S	T	U	V	W	X	Y	Z	Z

Thus the name "Blitz," is conveyed by:

C	L
o	e
l	t
u	t
m	e
n	r

1	2	Meaning first column and second letter,
2	3	second column and third letter,
1	9	first column and ninth letter,
		and
		so
3	2	This is learned without
		on.

3      8      difficulty in a few minutes.

## **Second Sight Through Brick Walls**

This is usually used for a hotel or press seance, i.e., for advertising purposes, and is claimed to be very striking.

The performer enters into conversation with some people in the hotel or office, wherever he happens to be, and makes the suggestion that his assistant's powers can be tested at a distance. One or more cards are generally selected, some initials may be chosen, a number in dice is thrown and a series of figures may be written down, dates selected and time of day noted. One or two gentlemen are chosen as messengers. They take any sheet of paper and envelope, with pen and ink and proceed to the assistant's room, wherever that may be, and hand her (it is generally a lady) the paper and pen without saying a word and in a few minutes she hands them a correct written answer to all their questions with necessary proper descriptions.

The manner of working this is as follows: Of course you arrange with your lady beforehand just what you are going to do. In this case let us suppose one card is drawn, one die is thrown, one number is thought of, one set of initials is written down, and the time of a watch or clock noted.

Fig. 1.

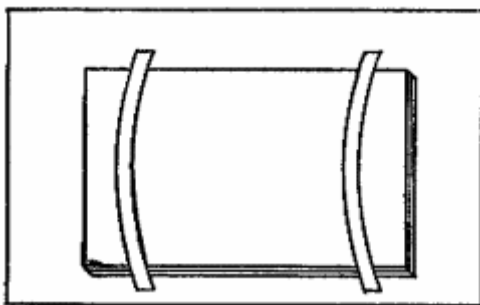

Now to the lining of the side of your coat pocket nearest the hand with which you write sew two short pieces of elastic cord in such a manner that they will grip neatly a book of cigarette paper, such as you can buy in any cigar store, (see figure 1.) The book cover is doubled back so as to leave one of the sheets of paper on top of it. In the same pocket have a very short pencil not too sharply pointed so as not to tear the tissue paper while writing on it. In your vest pocket have a common fountain pen. Thus prepared you are ready to perform the experiment.

Under pretence that you are not going to handle the articles you



keep your hand in your pocket most of the time, and this gives you a chance to jot down the various abbreviations for the answer. Of course what these abbreviations mean yourself and lady must know. In this case the following are selected: card selected, King of Hearts. Die, a six spot. Number thought of, 445. Initials thought of, E.H. Time of watch, 9:31.

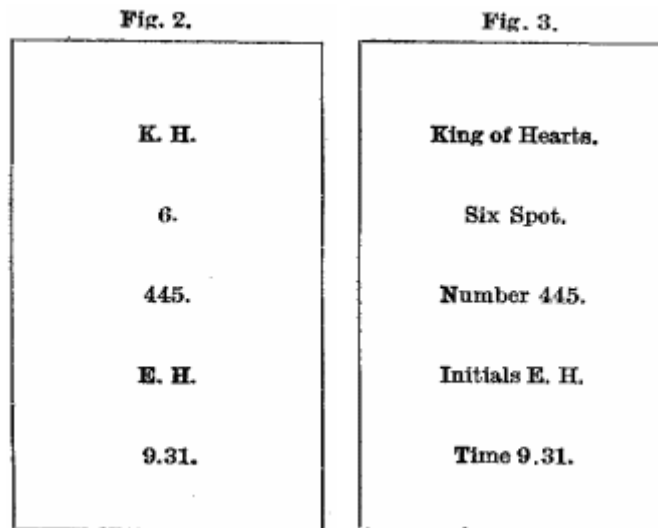

You jot these down as soon as selected and of course the difficulty of writing this way will not make the bit of paper (figure 2) a good specimen of calligraphy, but still it will be legible enough for your assistant to know what each abbreviation means. She knows that the first is a card, the second a dice, and so on.

While the messengers are being selected, tear this sheet off quietly and gently in your pocket and make a little ball of it, palm it near the tips of the middle and index fingers, which is very easy to do. Take out your fountain pen, and as you take off the cover part of the ease which protects the pen and which is always put on the other end of the holder while writing, you slip into it the little ball. This can be done very easily after very little practice. Do this while the attention of the spectators is taken up with the messengers, (selecting them).

The trick now needs no further explanation. When the gentlemen knock at the lady's door, she is of course, prepared to receive them. She takes the paper and asks them to kindly wait outside as the presence of strangers is irritating to her. She takes the ball from its resting place with a hair pin, smooths it out and translates the abbreviations into plain English and then writes the answer on the letter head which the committee has given her.

When this is done she opens the door and the gentlemen take back the answer, totally unconscious that they themselves carried the information as to what the answer should be. Dates on coins, birthdays, etc., may also be used. If you are a second sight artist you may use your numbers to indicate chosen articles.

## ***Psychonotism, or Silent Thought Transmission***

As introduced by Prof. Verbeck and Mdlle. Mathilde in Paris and London and Guibal and Marie Greville in England and America.

**Effect--**The performer, or better say, the professor, as there are two performers actually, advances, and with the seriousness of a hypnotist, announces the marvellous intuitive powers of his subject, Miss Venus. (?)

"Miss shall be hypnotized by me, and when launched into the hypnotic sleep, can and will perform any rational act that the spectators desire, despite the fact that I (the professor) will not speak one word during the performance. She will while in this trance walk among you and comply with your requests. This, ladies and gentlemen, is the trance-it of Venus. When I have her under control and in the hypnotic trance, I will move about among you, and you can convey to me by whisper what you would wish the medium to do, and you will find she will not fail in aught of your desires."

Miss Venus is now introduced by the Professor, she is pale and has two lovely black eyes. (?) Her hair, for effect, is loose on her shoulders. She is robed in white, a Galatean costume. She bows and smiles consumptively, and seats herself on chair facing spectators. The professor now, by means of any of the pantomimic gestures, pretends to hypnotize her, and she is or becomes hypnotized. (?)

Now performer goes among the audience, asking here and there what the spectators would wish the lady marvel to do, and having gone through say 12 to 20, he solemnly demands the strictest silence, and with serious mien advances toward medium without going on stage, and motions or waves his right hand in a downward movement in front of her. She slowly rises and goes through each performance desired, goes back to chair, slowly seats herself, and suffers (?) herself to be dehypnotized, then the performer recapitulates for the benefit of all what each spectator desired and how Miss Venus was successful in each and every crucial test.

**Explanation:** In performing this seance the performer must learn a code of signs and things, these things the professor forces into the minds of the people. Code to be learned for forcing:

1. Pull a gentleman's hair.
2. Turn up his trousers.
3. Tie a number of knots in his handkerchief.
4. Take watch out of gentleman's pocket and place it in another.
5. Open a lady's bag, take out her purse or anything she may desire.
6. From out of a number of coins placed in a hat, pick out the special one which has been selected.
7. Write any number selected on a card.
8. Take a gentleman's cane or umbrella and put it in the hands of another gentleman.
9. Take glasses off a person and place on own nose.
10. Take off lady's or gentleman's gloves.
11. Write down time by gentleman's watch.
12. Write autograph on programme gentleman holds.
13. Takes handkerchief out of person's pocket and ties it on neck or arm.
14. Ties a knot in watch chain, and so on.

This can be varied indefinitely as the reader must have already observed.

How to force these request. The professor pretends to hypnotize the subject, this as was said, is a sham, then going among the audience, he goes to number one, or first person, and asks this one what he would like her to do, he says, for instance: "Oh, let her tell me what I have in my pocket," or he would suggest some similar test. Oh, says the professor, you forget that she is hypnotized and we cannot have her speak, get her to do so and so, or this, or that, or so and so--and so the professor shoots out a volley of suggestions from his learned code rapidly, and as a natural result, the person selects one of these suggestions.

Going to the next he forces differently, and says, what shall she do for you? Turn up your trousers? Pull your hair? Tie a knot in your handkerchief? and so on. The professor here springs a volley of questions before gentleman has time to make any suggestions not mentioned by the professor, then seeing a lady sitting near with a bag, he says: Madam, have you a purse in it? Yes. Shall the lady remove it or anything else from it? and so on. Again you see a gentleman with glasses on, and suggest that

the medium move the spectacles, etc. If, however, gentleman does not wish this done, professor suggests some of the other tests, etc., etc. Remember medium's eyes are closed all the time, and in going through audience professor asks each individual his or her request in whispers only, and he generally has each person whom he asks a couple of yards apart.

Again it is better when forcing questions to force only three at a time, and force them in rotation. To do this we should say he suggests three questions, but emphasizes or forces one of the three. Now, the professor has to keep his wits about him, for having gone to a sufficient number of the audience, he must keep mental track of the gentleman who selected No. 1 of code, he who selected No. 2 and so on. When he goes to stage to wave down Miss Venus, all she has to do is to follow the professor in front or at side, and the first he stops at (by signal) she merely does first on code, the second he stops at, she does second on code and so on right through.

The professor must remember where each chooser is seated, for example, suppose these lines are rows of people, and each word is numbered and represents those whom the medium has to go to.

The professor directs his medium to the person by the movements of his hands, he first shows her the rows in which the persons are seated, all the time waving his hands as if making mesmeric passes, and as medium is walking along the people very slowly, as soon as she reaches No. 1 performer drops left hand at his side, and the medium stops and pulls gentleman's hair.

Professor then directs her to No. 9 and she is then stopped again, and she turns up gentlemen's trousers, and when she gets to No. 3 performer tells her how many knots to tie on handkerchief, by the number of downward waves of left hand, at the same time making passes with the right.

To select any special coin out of a hat or other receptacle, Miss Venus takes all in the hat in her hand, the right, and lets them drop one by one into the left hand, when she reaches the proper article, performer turns to audience, as if silencing them, and says "hist." Venus however continues pouring them into left hand, and when all are in, she picks out the one she knows is correct.

These methods may be readily varied to suit the performer, who

with a little skill and thought can work it up to most any extent.

Suppose something special and not in code is mentioned to be done, you have to whisper it to medium, and to effect this whisper, when in the middle of the test, you look around the audience, turning your back to medium, and you look as if you were looking for some person who selected something, and medium walks back to stage, you turn around, surprised to see the medium away from you, and follow her up, waving arms and hands energetically, and walk slowly around her, this near the stage, and rapidly whisper what you want to, at same time waving her back to audience, as it were, i.e. you leading her, you have to walk down aisle backwards and face to medium.

This of course can all be done while you remain on the stage with the medium, together with a committee seated about the stage, scattering your work among them, so as to avoid crowding about narrow aisles.

The medium's eyes appear to be closed all the time, but in fact are open sufficiently for her to see all movements of the professor. After becoming expert it will not be necessary to use the forcing code often, because all requests can be whispered to medium by professor without the audience becoming aware of it. He can do this when he escorts her from the stage to the audience, or as he occasionally passes her in the aisles, and the waving of his hands and arms in his different "passes" will partly tell her what she is expected to do.

This so-called Hypnotic demonstration has proven to be one of the most puzzling effects that have been introduced for many years.

## **The Spirit Thinkerphone, or Marvelous Vision**

**In effect as follows:** Performer walks into a newspaper office and asks someone to think of a card in an imaginary pack of cards, after he has done so to write the name of the card in his note book or on a slip of paper, and keep same in his pocket, then party writes a note asking name of card, and encloses note in an envelope which he seals and addresses to the performer's assistant. He then calls a messenger to deliver the note to the assistant at the hotel and return with answer; he does so and the answer is found to be correct.

**The explanation is as follows:--**There are four suits in a deck of cards, viz. Hearts, Clubs, Spades and Diamonds. Each of these commences with a different letter. Performer watches party as he starts to write name of card. Suppose for instance it is the five of spades. As soon as he sees the number 5 written down he watches to see what suit it will be. This he knows as soon as he sees the first letter put down, which in this case is "S." He then turns his back in order to avoid watching the person finish writing the name.

The information as to what the card is, is conveyed to the assistant by two finger-nail marks on the envelope, one on the back and one on the front. The front of the envelope is divided into 12 imaginary spaces (see figure 1). At one end of the back are the places for the marks to represent the suit, hearts, diamonds, and spades (figure 2). If the back has no mark it is a club.

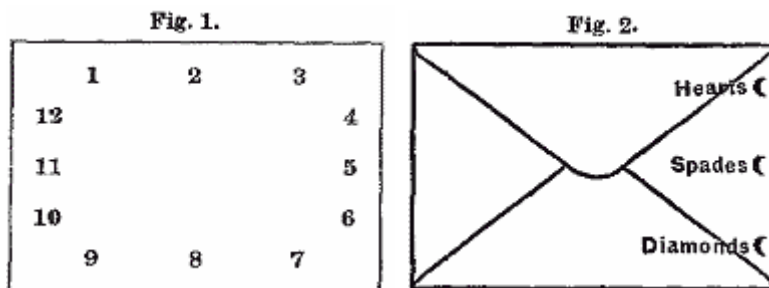

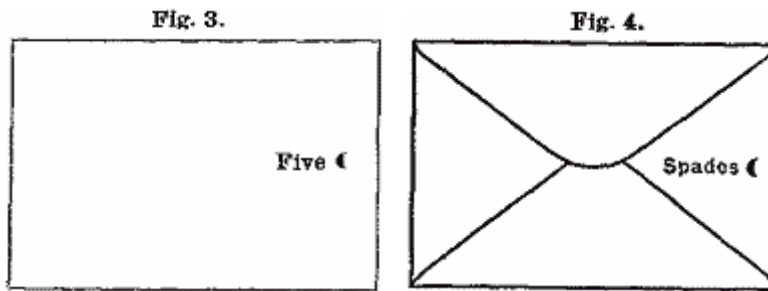

The front of the envelope represents the number of spots on the card. One for ace, etc., eleven indicates the Queen, twelve the King. If the card is a Jack there will be no mark on the front. In this case the card is the five of spades. In picking up the envelope the performer marks it front and back as shown in figure 3 and 4. Or the envelope may be marked after the note is enclosed in it. This may be done under pretext of examining it to see if the address is correct.

If required to repeat the test the performer may vary the modus operandi by addressing the envelope himself and doing away with the fingernail marks. This is done as follows: Take the first 13 letters of the alphabet as the initials of the person addressed and also let them represent the 13 cards in suit.

A	B	C	D	E	F	G	H	I	J	K	L	M
1	2	3	4	5	6	7	8	9	10	11	12	13

Now if you wish to communicate the card "10 of hearts," the address on the envelope would be as follows:

MR.           JOHN  
SMITH,  
Auditorium  
Hotel.

The initial "J" indicates 10 and the first letter of the place (Auditorium Hotel) coming under the first capital letter of the name indicates "hearts." The suits of the cards are indicated by the capital letters in the name. The first capital letter means hearts, the second one spades, and the third one means diamonds. If no capital letter is indicated the card is a club. The particular capital letter you wish indicated has the first letter of the place addressed placed immediately under it.



## ***Taschypsychography, or Long Distance Second Sight***

A plain, ordinary kitchen table is brought upon the stage, and a committee of ten is called for from among the audience. The manager then says to the committee:

"Gentlemen, five of you please take the mind reader outside of the hall and keep him in charge for half an hour." Five of the committee take the mind reader outside while the other five watch the man on the stage.

A watch is borrowed from the man in the audience. The manager then asks one of the committee at what time he should stop it. The watch is stopped at 3 minutes past 12. The manager sees this and places it carelessly on the table.

A cigar case is borrowed and the manager asks for a number of cigars. The case is filled or partly filled with say 6 cigars or as many as the committee decides on. The manager then carelessly lays it upon the table.

He then asks one of the committee to write the name of some friend, the first name only, upon a double slate, which is then handed to someone in the audience. The pencil is then laid on the table.

He now requests the committee of five to take him outside and to keep him until after the mind reader has finished. The committee does so and the mind reader returns. He at once sees the watch and the committee asks him what time it is by the watch. The answer is 12.03, the watch is opened and the answer is found to be correct. He then tells that the number of cigars is six in the case and that the name on the slate is Harry and the number in the sealed envelope is 94. All prove correct.

**Explanation--**The table which must be a round one is divided mentally into 24 pairs, 6 in a row and 4 deep. There are no lines upon it, but the mind reader and manager have made a mental division of it with a pin in the centre to guide them, if they are a little clumsy; they can readily see any of the 24 divisions mentally, each square represents a name, 24 common first

names.

There is also an imaginary face of a watch upon the table, the XII being towards the audience and the VI being opposite. The watch is laid with the ring toward the audience which means 12 o'clock, it is laid in the third space marked off mentally, which means 8 minutes after 12, if it had been stopped at 19 minutes after 3 it would be laid on the right hand of the table. The ring would be pointed to the right, which would mean that the hour hand was set at 3, the 12th space indicates the minute hand.

In case the watch was stopped 52 minutes after 12, it would be laid face downward, which indicates that the time is a half hour past the hour at which it is (laid) stopped, plus the spaces in which it is laid.

The slate pencil is laid in the space marked "Harry," and the mind reader knows that Harry was the name written on the slate. The cigar case is lying in the 6th space and means that there are 6 cigars in it. The lead pencil is laid in the 9th space pointing toward the 4th place and indicates that the number is 94. If it was 944 an envelope thrown carelessly on the table would mean a repeater for the last number.

Any number of tests may be introduced on the above plan. The committee are satisfied that there has been no collusion and their report is to that effect.

## **Hypnognotism**

The feat called Hypnognotism is in effect as follows: Performer introduces lady and after hypnotizing her, blindfolds her, by placing a hood or bag of impenetrable material over her head, which fastens by tightening a cord under her chin or around her neck. This bag or hood is examined beforehand, placed over flame of candle, to prove that it will not even show light through it, and is placed over spectator's head, who will vouch for it being impenetrable.

On the stage is a large easel, with large sheets of glass in an upright position. The glass is removable and can be replaced by another sheet when necessary; on a small table are crayons of various colors, placed so the performer knows the place of each color, and a stick of soap with which to draw on the glass.

Performer announces that for the first test, he should like to have some spectator whisper in his ear the name of any object, or design which he desires drawn by medium, say an animal, flower, cross, anchor, face, etc. When request is whispered into performer's ear, for example; "draw an elephant," the performer faces the medium who rises from chair, takes up crayon and draws the elephant. Performer does not speak one word, or make any gestures, or even walk.

For second test performer says: "we will now draw in the same manner, a composite, or combination picture, either a landscape, marine view, fruit picture, or anything else. Various spectators will please suggest the composite part of the picture." He steps up to someone and asks: "shall it be a landscape, marine or fruit?" Say a landscape is chosen. He then asks another spectator: "shall we have a clear or clouded sky or a sunset?" Next he asks: "shall we have a mountain in the background," etc., until he has collected ten or twelve requests for the composite picture, like this for instance: landscape with lake, waterfall in background, 2 large trees in front, shrubbery, a road-way, fence, 3 ships on lake, birds in air, sunset, sky, etc., of course performer must take care that no one suggests ships when there is no water, or lighthouse in a country landscape.

The next test is a coin test.

Performer asks for a coin of any value and says the medium will draw it in yellow if gold, in white if silver, blue if nickle, red if copper, so as to show its value and date, then medium draws picture. It appears reversed on the glass.

The next test: A visiting card is asked for and medium steps over to glass, and standing behind it writes the name backwards, thus: .htimS .N .J It will read from front side of glass: J. N. Smith. The reason for doing this will be seen later on, but audience are told that picture or object seems to be reflected upon medium's mind as a picture in a mirror, and while that makes no difference in drawing flowers, since they appear the same, but it does make a difference in names and figures, that is why glass is used instead of paper in all tests where letters or figures are transmitted.

A watch is asked for and owner sets it at any arbitrary time. Medium draws it as if it were figures, that is, as it would appear in a mirror.

Number, series, and value of bank note is transmitted next.

If it happens to be anything but a U. S. Treasury note, the name of the national bank is also included. A number or figure is whispered in performer's ear, and lastly a word or name of a city or of an eminent man is whispered to him and they are reproduced by medium. Other tests may be introduced ad libitum, such as a domino being selected and drawn, a word from a book, etc., etc.

**Explanation--**First to be explained is the bag or hood or blindfold. Get some black or very dark flannel and crape such as used for widows' veils. First make a bag of flannel to fit over the head, neither too loose nor too tight. Now cut your crape in same shape, but about a quarter of an inch wider and one or two inches longer, so as to fit over the flannel bag, making a hem from three quarters to an inch wide; through it run a ribbon or string with which to tighten bag around neck. Now sew the hem to the flannel, but only half way around, this will admit of putting head between crape and flannel, as the crape is transparent, medium can see every move, or motion of performer.

When you are ready to use hood, prepare it by taking black thread, place into a needle and at the end of the thread, before

knotting, place a small black bead, then sew up the open side with loose stitches and leave the bead on the inside; draw up until bead is close to cloth, and cut off the thread on the other end nearest needle.

The hood will stand temporary examination, while performer turns with it to stage, he simply takes hold of the bead and can withdraw the entire thread with one pull. The head of the medium is placed so he or she can see through the crape and the string is drawn around the neck, this is the reason that the hem is only in the crape and not in flannel also.

While the medium can see everything, her face cannot be seen, when the proper kind of crape is used, neither too thick nor too thin; there must be no light directly behind the medium.

If one thickness of crape is too flimsy, use two.

The transmission of the requests of audience depends upon a kind of finger alphabet, or deaf and dumb language, there being several kinds, but the following method is most serviceable and if the performer uses judgement, no one will attach the least importance to it, and yet he will be able to transmit almost any desired word in five seconds.

The letters of the alphabet as well as the figures are given by playing with the watch chain, and the right hand alone gives them. Therefore, first let us say, that performer making his introductory speech or lecture, already should play with his chain, twist it around his finger, etc. The left hand has nothing to do with these signs, it is used to transmit other information. Here are signs for the left hand first.

**Code "A"**--Left hand and arm hanging down by side: I am giving numbers. Left hand akimbo at hip: I am spelling something. Left hand at lapel of coat, near top button: I am giving abbreviations. If left hand moves slightly, say three inches or so, while in any of these positions: I am giving a color by its number. Shifting your weight from one foot to the other, means: I am starting or I am through.

This last sign is used in the following way: If performer only kept his right hand at the chain when necessary it might arouse suspicion, therefore the medium must receive some signal when the performer commences signalling. That is done by standing with the legs a few inches apart; and-shifting the weight of the body from one leg to the other, which gives a kind of swaying

motion to the body scarcely noticeable to the uninitiated, but enough for the medium.

When through giving signs, instead of always moving hand from the chain suddenly, which would also be suspicious, keep your hand there but shift your weight back to the other foot, meaning, "all through," then even if you keep up the playing with the chain, medium knows that there is no further meaning to it.

**Code "B"**--Next we come to the signs of the right hand. We will first explain the 10 figures: It is to be presumed that the performer wears a dress coat, with a low cut vest and carries his watch in his lower left hand vest pocket, with the staple in second or middle button-hole. It is advisable to have the chain several inches longer than usual length. The chain itself has nothing to do with the signalling, it is the right hand alone that must be watched by medium and on whatever portion of the vest the finger-tips rest, indicates what number is meant.

For figure 1, pick up chain at "X", its middle, and place fingertips against bottom of vest, directly in a perpendicular line from the watch pocket. No. 9 Fingertips at watch pocket.

No. 3 Above watch pocket, near upper pocket. One, Two and Three are on the left side of the vest.

No. 4 At bottom of vest where the two parts of vest meet.

No. 5 At or near the staple.

Four, Five and Six are in the centre of vest, for cipher the sign is made by twisting the chain around right thumb, without the help of the fingers. The chain should generally be held by its centre when it will be easy to reach the various portions of the vest. For One, Four and Seven, go as low down as the chain will permit, for Three Six and Nine as high as you can.

Suppose you had to transmit 1892, which is whispered into your ear. While still bending down to the person who whispered to you, you take hold of chain at "X" in an aimless way, and straightening up face the medium, let your left arm hang, which means, I am giving numbers, and when you see that medium is ready for you, shift your weight, which means, "begin"; at the same time place the right hand at One, that is, let the fingertips touch the bottom of the vest below the watch pocket.

The hand must not be stiff. It can play with the chain, twirling it slightly, but it must be at One, leave it there a second or two and then slowly take it to Eight. Do not make the movements jerky, but deliberately and aimlessly, and remember that no matter if the hand is held from above or from the side, the tips of the fingers must be at the figure.

Then follows Nine, that is, you simply bring your hand about two or three inches higher up, still playing, and then finally take it slowly and carelessly to the watch pocket, which is Two. Never drop your chain suddenly, but shift your weight, which means all through.

The entire signalling should not occupy more than from 5 to 8 seconds; with practice, 30 to 50 letters per minute which is about one word in 10 seconds can be communicated, long words may be abbreviated.

We now come to a description of the alphabet. We omit K and Q at first. A is made just as figure one, B as two, C as three, D as four, E as five, F as six, G as seven, H as eight and I as nine. Then we begin over again: J is one, L is two, M is three, N is four, O is five, P is six, R is seven, S is eight, T is nine, but for these letters J to T shake the chain a little, while in former case, A to I, hand is held almost quiet, twirling the chain slightly will not give a decided motive. Shaking the chain gives a decided up and down motion to the hand and is distinctly visible even at 50 or 60 feet distance.

Care must be taken that the finger tips remain near the places one, two, etc., and not midway between any two numbers. Practice before a mirror, so as not to get the habit of looking at the hand, and see that the movements look careless and not stiff, jerky or violent.

The letters U and W are given same as cipher, by twisting chain around thumb, describing a circle with hand, but in U, circle is made at 4, 1, 2 and 5 that is, on the lower left side of vest, in W it is made at 5, 2, 6 or upper left of vest. The remaining letters K and Q are given by twisting chain around first or index finger this will make the circles go in the opposite direction.

The remaining letters are given by a kind of whip movement.

Grip the chain tightly between first and second finger and thumb, and make a stroke up and down, as if the chain were a whip. This will give to the hand a kind of violent up and down

movement. If made in centre of vest and only once it is a Y, if near numbers 4, 5, 4, if twice in quick succession it means Z. If at watch pocket twice, 1-2-1-9, it means X.

This alphabet should be thoroughly learned and diligently practised, using small words to start. To show where one word ends and the next one begins, drop chain from right hand, remove hand three or four inches and then pick it up again at X for next word.

Don't forget to shift your weight at beginning and end of sentence. If figures are mixed in with words, for example, house with three windows, drop your left hand at end of "house with," to side, and make the three, then raise it again to hip and spell the next word.

**Code "D" Colors**--No. 1 red, No. 2 white, No. 8 blue, No. 4 black, No. 5 brown, No. 6 yellow, No. 7 gray, No. 8 green, No. 9 silver, No. 0 gold. See code for color signs of left hand. Take a complicated example, white house with red doors, and three yellow windows. Play with chain until ready, left hand at hip, "spelling," shift weight, "ready," bend elbow back, "giving figure 2," which means color 2 or white, elbow forward and drop chain, "end of word," pick up chain and spell "house," drop chain, "end of word," bend elbow back, "color," pick up chain and give No. 1 meaning color 1 or red, elbow forward again, drop chain, pick up again and spell door, drop chain, end of word. Drop left hand to side, giving figures and make 3, raise left hand an inch or two, which means color in that position, (see code A) give 6, color 6, or yellow, drop chain, raise left hand to hip, spelling again, pick up chain once more and spell window, shift weight.

This last example is given without trying to abbreviate and is necessarily much longer than could be accomplished by abbreviations. We will now give an example of code used in abbreviating and which one can follow or improve on to suit themselves.

### ABBREVIATIONS

<b>Class animals</b>	<b>A, Class birds</b>	<b>B, Class designs</b>	<b>D,</b>
A, antelope	C, chicken	A, anchor	
B, bear	D, ducks	C, cross	
C, cat	E, eagle	H, heart	
D, dog	G, goose	M, Maltese	



E, elephant O, ostrich etc. cross  
S, star

---

**G, Geometrical**      **H, Houses**      **I, Insects**  
A, angle      C, church      A, ant  
C, cylinder      M, mill      B, butterfly  
D, diamond      T, tower      F, fly  
E, ellipse      S, street      S, spider  
O, oblong  
S, square etc.

---

**M, Man**      **F, Fruit**      **L, Landscape**  
**Pictures**  
A, angel      A, apple      B, boat  
B, beard face      B, banana      M, mountain  
C, child      C, cherries etc.      T, tree  
F, face etc.      L, lake

---

**M, Marine View**

S, ship  
L, lighthouse  
R, rocks  
B, little boat  
etc.

If you get a suggestion whispered, say an elephant for example, you face medium and give C, A, E--C for class, A for animal, E for elephant, etc.

**Test No. 2, drawing of compound pictures.** Make a separate list of abbreviations for the various articles forming the picture.

After collecting the various suggestions, turn toward medium and give her in 4, 5 or 6 letters and outline. The first letter showing whether it shall be a landscape, marine view, or fruit picture. For example, L. M. L. H. R., meaning landscape with mountains, lake house and road. This can be transmitted in

about 5 seconds, medium picks up crayons and makes a rough outline of picture in black, then turns and while picking up the necessary colors of crayons gives the details, for example: 9 T, two trees. 3 B, three boats, and in this manner proceed until the entire picture is finished.

**Card Test**--If a plain card, left hand hanging.

If a face card, left hand at hip. 1, clubs, 9, diamonds, 3, hearts, 4, spades. 1, ace, 2, deuce, 3, tray, 4, four, 5, five, 6, six, 7, seven, 8, eight, 9, nine, 0 ten, hand hanging. 1, Jack, 2, Queen, 3, King, hand at hip. For example, King of spades: place hand at hip, and give 3-4, the 4 for spades and the 3 for King. For six of diamonds, hand hanging, give 2 for diamonds, 6, for six.

**Coin test.**

<b>1--Gold</b>	<b>2-- Silver</b>	<b>3--Nickel</b>	<b>4--copper</b>
1-- \$1.00	1--3 cents	1--3 cents	1--one cent
2-- \$2.50	2--5 cents	2--5 cent old style	2--continental coat
3-- \$3.00	3--10 cents	3--V or new style	3--2-cent new style
4-- \$5.00	4--20 cents		
5-- \$10.00	5--25 cents		
6-- \$20.00	6--50 cents		
	7--\$1.00		

The date is given backwards, and the century if 18, is omitted, if 17, the 7 only, is given, for example a 50 cent piece of 1863 is transmitted by 2, 6, 3, 6. The first two shows silver, the six shows 50 cents, the three is the last and the six the second last figure of date, this would be drawn by medium, reversed. The performer explains this by saying, the medium follows the dictation of my mind, but appears as though all suggestions are not caught as given, but exactly the reverse, as a picture in a mirror, or a negative in a photograph.

This bluff enables the performer in all such tests where spelling is necessary, to give the signs at one time, for the medium standing behind the glass facing performer and does not have to

turn around as would be the case in drawing on the paper.

The coin test paves the way for the visiting card test, ask for any visiting card and spell the name backwards to medium, first give her two letters, when she has drawn the first one, or really the last one, give one more and in that manner keep one letter ahead all the time.

The watch test is similar to coin test, but it is done on the glass.

1-Gold hunting case. 5-Silver hunting case. 3-nickel hunting case. 4-Gold open face. 5-Silver open face. 6-Nickel open face. Left hand at hip if stem winder. Left hand hanging if key winder. Example-Gold open face watch with extra dial for seconds and stem winder, time 4.48. Signs, left hand at hip, stem winder. 4-Gold open face, shaking chain, little dial, 3. 4-6, making 4 signs in all. This drawn in reverse on glass which from front will show 12 minutes of 5, gold.

The figures may be omitted in drawing, to save time.

**Bank note test:** This will hardly need description. 1-equals \$1.00, 2-\$9.00, 3-\$5.00, 4-\$10.00, 5-\$20.00, 6-\$50.00, 7-\$100.00, 8-\$200.00, 9-\$500.00, 10-\$1000.00.

You spell and give the numbers backwards, just the same as in visiting card test, giving the value first.

**The whispered word test--**This test is executed just like the visiting card test, spell backwards, one letter at a time and written on glass.

Other tests will readily suggest themselves and in fact they are without limit.

The tests should be so arranged that each varies from the one preceding it. Don't introduce a visiting card and a whispered word test in succession. They are too near alike.

## ***The Great Shooting Act***

A file of soldiers march out from a line, one on each side of stage. The one in command takes each gun separately and hands same to performer who looks through barrel, then hands same back, until all six guns have been inspected. Then performer steps to one side of stage.

The commander now calls for cartridges, each man takes a cartridge from his cartridge-bag, commander collects them on a plate, where the soldiers deposit same. They are now handed by the commander to the audience for inspection, and are marked by audience for identification.

Commander collects cartridges on plate goes to stage and hands each soldier a bullet. The soldiers hold up the bullets till the last moment so audience can see them. Commander now orders them out on foot board, about forty feet from performer. Commander gives orders to aim and fire, which they do and performer catches the bullets.

Explanation--The Springfield Rifles are "O.K." The cartridges are fixed, that is, the bullets are only fitted into shell tight enough not to come out easily, so as to allow inspection, (people do not generally try to pull at the bullet.) Each militia man gets one of these bullets which when order for bullets is given are handed to commander, he allows them to be inspected, marked, etc., then collects same on a plate.

As he returns to stage he goes as far back as possible, while doing so he changes the cartridges, substitutes cartridges that have wax tips formed like a bullet, coated with plumbago. The soldiers hold up these bullets. Audience cannot distinguish but that the bullets are "O. K." These are loaded into rifles, the effect when fired is same as a blank shot.

When commander returns with plate on which bullets have been collected, he leaves the real bullets, which are quickly extracted from the shell and handed to performer, who apparently catches them when fired at him.

## ***Head of Ibykus, or Talking Skull***

While your assistant shows the head around to the audience holding it on a platter or server, you put two chairs back to back, a short distance from each other.

At one side of stage is a small table on which lies your wand and over the wand lies a strong black thread, both ends of which lead off to your assistant behind the scenes or in the next room. Near this table stands a sheet of glass, which has been ground smooth on both sides. You fetch this, let it be examined, and as you return to stage, place it upright in your left hand, and let it lean against the left shoulder.

With your right hand pick up wand, thread with it, lay the hand on the upper narrow side of the glass plate, hold it out in front of you flat, i.e. level, and assistant lets thread loose enough and holds both ends wide apart, so that the middle lies around the right narrow side. As soon as this is done, place glass on the chair backs, pressing it down on the four corners where it strikes the chair sides, on top of which it rests and on each one of same is previously put little wax so glass rests securely.

Now assistant has the thread under control, it goes from his right hand over and across the glass, around the narrow side and back to his left hand, and he can pull it back and forth without its sticking.

You now take head, place it on glass behind the thread and take the upper thread, which assistant lets loose a little and loop it once around the pin in lower jaw. Now if assistant holds left thread securely and pulls on the right, the head nods, and if he pulls first one and then the other to and fro, head moves back and forth on glass. First meaning "Yes" second "no." Now you can put a globe over it to show there is no connection, but see that a foot is on the globe or a slit in it, that is towards front, so thread can move easier.

Now of course head answers questions, and tells chosen cards, and always looks or turns sideways whenever you face audience, but when you face it, it faces you or straight ahead as though

nothing had occurred. This always awakens laughter, and finally you catch the head at it, and ask why he is always looking to one side, if his bride is there? And he answers with a yes. And so on, tells age of person, how many years before a young lady will marry, if she will be blessed with children, etc., etc., and to last question it keeps on nodding (knocking or rapping) till you command it to stop, and immediately goes at it again.

Now ask one or two gentlemen to come up and lift the glass globe and examine all. Before gentlemen get there; ask the head if he knows them, no. Ask if they can come up and examine him, yes; and as they approach, assistant lets upper thread loose, and pulls the lower slowly and quietly, and loop works off the pin and then pull in quickly so gentlemen can examine. If head is to answer by moving jaw, etc., take out the pin from upper right back of lower jaw, and then jaw moves on pulling the thread.

If head is to smoke, place it on table top, in which are two ferules fitting into holes in bottom of head, from the lower ends of these lead out two rubber tubes, back to assistant. Place a cigarette in left opening between teeth, hold match to it, assistant draws and blows smoke through the other tube, if smoke is not strong enough, assistant has another cigar to smoke, and head quietly smokes the cigarette while you prepare for another trick.

## ***The Mango Tree***

The rod of the table which may be a glass topped one, contains a piston, to which are fastened or rather hinged, ribs of an umbrella, the whole contrivance lying folded up in the hollow leg of the table. When the string of piston is pulled, the latter raises above surface of table and the hinged arms spread out by their own weight.

The piston rod has branches or arms which are made to resemble branches of a pink plant or rosebush by attaching to them feather leaves and flowers. (Pinks folding smaller than roses are preferable.) The flower pot used is a double one consisting of a heavy outside bottomless shell, the inside pot proper being made of tin and filled with sand.

After being examined the inside pot is got rid of, leaving only outside pot which is placed on table. In due time the piston raises and under cover of the handkerchief laid over the pot, the tree expands and visibly grows, till at last it has attained its proper height. It is then shown and the flowers which are detachable, are, apparently snipped off and thrown over into a basket, which is exchanged for a similar basket of natural flowers, which are then distributed to audience.

## ***Queen of Knives***

Have a large block of wood about one foot in diameter, fasten into the floor or ground, it is about 3 feet high and round. Have a knife about two feet long, four inches wide and 1-1/2 inches thick. (It is made like a corn cutter) with a handle. This is driven into the wood, the sharp edge, and with a sledge hammer drive it down further. Have an iron bust (corset) or apparatus like the old "Suspension," but it works in the back of lady.

Lady keeps her legs crossed when she is placed on the knife. The notch must fit "snug" over the edge of knife. She wears a fancy "Mother Hubbard" dress, with a 4-inch lace collar to hide the iron notch. When lady walks the iron is between her legs. It is made long so she can rest when laying on it.



## ***The Appearing Lady***

On the stage is a platform which is raised above the floor by four legs about 6 inches high. On this platform are four upright, s, one at each corner, this forming a frame on which to hang the curtains. Back of this there is a screen made of red calico. The performer goes behind the platform and pushes a stick through to show that there is no mirror, etc., underneath it.

The performer and assistant now prepare to put a curtain around the frame work. Performer and assistant each takes hold of the curtain and pull against each other to show that there is nothing concealed in it. This is done in front of the platform and conceals a small mirror being dropped under the platform by an assistant below the stage. It is dropped at an angle to reflect the bottom of the platform which is covered with the same kind of cloth as the background.

Performer and assistant take the curtain and place it on the frame work and form a cabinet. Performer standing in front holds the curtain with one hand and counts 1-2-3, curtain opens and there stands a lady dressed in white. She comes through a trap in stage and platform, the small mirror preventing her from being seen while ascending. Or have only trap in stage and let her come in the cabinet through a slit in the back.

## ***The Escape from Sing Sing***

For the illusion you have two cages, each 7 feet high and 4 feet wide and 4 feet deep. Each cage rests on 4 legs which elevate them eight inches above the stage floor. The sides and the door have dark red curtains and the back has a curtain of the same color as the stage is draped with; usually a dark gray to represent a cell.

The sides, front and back of the cages also have wooden rods running up and down. These are blackened so as to look like iron, they are about half an inch thick and are set in the framework of the cage about 4 inches apart. Three or four of these rods are loose at the back and can be moved so the prisoner can come through.

Each cage has a small shelf at the back for the assistant to stand on. To work this illusion you require two men dressed alike as prisoners and one dressed as a policeman or guard.

When the stage curtains go up the cages are standing well back on the stage. Cage number 1 has all curtains up and the performer walks behind this when entertaining. Number 2 has back curtain down and as it is of the same color as the stage background, the audience do not see it nor the guard who stands on the shelf behind it.

Now prisoner number 1 rattles chains in the wings and comes running on stage. Performer stops him at point of revolver and puts him in cage number 2, and closes the door and pulls down the curtains. Soon a voice is heard calling, "let me out," performer opens the door the prisoner has gone and there stands the guard.

At this moment the prisoner comes running in through audience to stage. Performer and guard seize him and put him in cage number 1, and close doors and draw blinds of both cages. Fire pistol. Open cage door and blinds of both cages and behold the prisoner is seen in cage number 2.

You see that when performer puts prisoner in cage number 2, he

removes the back bars, lets down the curtain and changes place with the policeman, who raises curtain, puts back bars and then calls to be let out. The other prisoner then rushes in through the audience. Now when they put him in cage number 1, he gets behind the curtain and the prisoner in cage number 2 comes into cage and leaves the back curtain up.

## ***Rapid Transit***

A wire is run across the stage. On it are hung two screens about 7 or 8 feet apart, and about 18 inches above the stage. Screens are plain wooden frames covered with paper or cloth. Behind each screen placed a stool, the screen hanging about two inches below the top of the latter.

The performer gets on a stool behind one screen, and extends his hands to show that he is really there. Then he draws his hands back, and in one instant, he is transferred invisibly behind the other screen. Here he shows both of his hands, and travels in an instant behind the first screen, and then he steps out before the audience.

**Explanation:--**The frames are covered with paper or cloth, and are hung by two hooks, screen 1 is unprepared. Screen 2 is prepared as follows: It has two stuffed gloves behind it and a cord, holding the dummy hands behind the screen, the cord leads behind the stage to your assistant.

Performer gets on stool behind screen, extends his arms and shows his hands. Performer now draws in his hands behind the screen, and the assistant slacks on cord and the stuffed hands behind screen 2 drop out of their own weight, and represent the performer's hands. These false hands have white gloves on same as the performer, who has now apparently travelled behind screen 2. Now assistant pulls string. This causes the dummy hands to fold behind screen 2 and performer extends his hands from behind screen 1, and then he steps out before audience.

## **Noah's Ark**

On stage is seen four uprights, upon which rests an elegant casket, in appearance of an antique boat; in the front side of it are two windows. Performer removes the cover and lets down all four sides to the stage, to show that nothing is concealed in it; the sides are closed up again and cover put on.

A large funnel is now placed in a hole in top of cover and the performer proceeds to fill the casket with water, bringing on pails of water to do so. After water is poured in performer opens the windows and takes out a large number of doves, rabbits, ducks, cats and all kinds of articles, etc., then removing cover, white clouds ascend and a lady is seen rising out of the casket, dressed to represent the rainbow. This is a first-class sensation, and a sure hit. No mirrors, black curtains or reflections used.

**Secret--**The front and back and both ends let down to show empty. There is a small shelf on back of boat where girl is. You let front down first, then ends and back. Front and ends keep audience from seeing girl on back when it is down.

Put back up first then ends and front. Then pour in water and put on the boxes. As soon as front is up girl opens back and connects rubber hose to end of funnel which is placed in hole on top, the other end she places in hole on top of one of the legs, (all four of the legs are hollow and will hold a large pail of water,) after each pail of water she places rubber tube in different leg until four pails of water have been poured into top of boat.

As soon as done girl takes animals out of one of the compartments and places same in box nearest that end and then she takes some out of the other end and then back to first end, and soon until all the things have been produced. Then in due time she pushes up the lid of boat and makes her appearance on top of boat. Lady should be dressed in a very handsome costume.

While performer takes stuff out of one of the boxes girl is loading other box, these boxes form the ends of ark.

## ***The Oriental Barrel Mystery***

On stage is seen standing a platform about twelve inches high. Performer going behind platform pushes a sword through underneath it in order to show that audience can see beneath it.

He then shows an ordinary newspaper and places this upon the platform. Then he brings forward a common ash barrel and puts this on top of the paper and platform. He then introduces the young lady with whom he is going to perform the illusion, gives her a pistol and places her in the barrel, and tells her to crouch down so that he can put the cover on.

Performer then asks lady to hold out the revolver and one of her hands from beneath the cover so audience can see that she is there all the time. The barrel is held together with two hoops, one at the top and one at the bottom, and by a piece of string tied around the centre. Performer commences to remove the hoops, the bottom one first and then the top one. The barrel is now held together by the string only.

Lady is instructed to shoot when he says three. Performer counts 1-2-3 and at the word "three" pistol is heard, the barrel falls apart, the lady is gone; audience look up in the gallery and see lady standing there.

**Secret--**When performer introduces lady all eyes are naturally turned upon her and audience fail to see that a curtain is lowered between the two front legs, by an assistant beneath the stage. There should be a screen of the same color behind the platform. The barrel platform and stage each have a trap in them so the lady can go down. The newspaper is also prepared by being mounted on stiff cardboard and this also has a trap cut in it.

When the performer tells the lady to crouch down she goes through the trap, beneath the stage and hurries up into the gallery or other place of appearance. The assistant immediately pushes up, by the aid of a rod a pistol and dummy hand. The hand is made of a stuffed glove which is the same color as the one the lady wears.

The performer takes his time in removing the hoops of the barrel in order to allow the lady opportunity to reach her place, when he starts to count 1-2-3, the assistant underneath the stage takes in the pistol and dummy hand and closes the traps. At three the lady in gallery shoots the pistol. At the same instant the performer cuts the string and the barrel falls apart.

The construction of this illusion is as follows: The bottom of the trap is a solid wooden rim with a star trap in the centre, each stave is fastened to this rim with a hinge which helps to hold the staves together when the string holds them without the hoops, but which will allow them to fall outwards when the string is cut. The lady should wear an Eastern costume.

## ***The Artist's Dream***

This wonderful and charming illusion is meeting with great success in England. A large frame with a curtain in front rests on a three step platform on stage. Artist pushes aside the curtain, removes canvas with picture of lady on it from frame, turns canvas and frame around to show that no one is concealed anywhere about the frame and canvas. The canvas is then replaced in the frame, curtain drawn in front of frame and the artist seats himself on a chair, apparently goes to sleep and dreams that the picture came to life.

While in pretended dream curtain opens and a living lady steps from the frame, artist awakens and sees her. They exchange a few words, then she goes back into frame; artist says, has my model come to life or have I dreamed it? He goes to the frame opens the curtain and there finds only his painted canvas; the lady having vanished.

The canvas with the painting on it is on a separate frame or stretcher which is very heavy, the top piece of this frame is hollow and contains a roller on which the canvas rolls up the same as the curtain in the watch frame.

On the back of the stretcher on each side is a handle, these handles are apparently placed there for the artist to lift the frame in and out by. But they serve another purpose which will be stated below. At the top corners of the stretcher are fastened two wires which lead up to the flies, over a pulley and then down behind the screens to the assistant, when the wires are slack the stretcher may be turned around just the same as if they were not there. The large frame is on rollers and may be turned around to show that there is nothing concealed in or behind it.

After showing frame and back and front of canvas artist sets the canvas back into the frame. When the canvas stands on the floor in position to replace, the lady comes up through trap door behind the canvas which conceals the movement, she takes one of the handles referred to above in each hand and places her feet on the lower part of the stretcher which projects enough for



her to get a passable footing.

The artist now raises the canvas back into the frame. The wires attached to the stretcher are pulled by your assistant, this makes the lifting of the stretcher with the lady on it easy enough. Now all the lady has to do is to unfasten the canvas and let it roll up into the stretcher, she now steps out on the stage from under the curtain. After she goes back she lowers the canvas and hooks it. The artist then pushes aside the curtain and finds only the painted canvas.

## ***New Half Lady Illusion***

In the centre of the stage or on a platform is seen a half lady resting on a wooden horse with 4 legs.

The stage or platform must be 4 feet high. The trestle is 3 feet high and 3-1/2 feet long. On the top of the centre of the trestle make a bust like that used in "Swinging half lady" and have it ironed on the trestle and finely finished. Black cloth is tacked to the back of the two rear legs. The walls at the back are draped with the same kind of goods. Have a framework in front and partly over lady, on which you hang curtains.

When you open the curtains audience sees the half lady resting on the trestle. The lady is behind the trestle resting on her knees, and leaning against the bust, which should be dressed in some light color. No lights are needed to shine inside as the front curtain hides everything. Have it very dark at back of front curtain and the trestle fastened to the floor.

## ***Edgar Poe's Raven in the Garland of Thebes***

A fine raven sits in a beautiful garland of roses, suspended in mid-air by two ribbons, bird talks, sings, whistles and tells fortunes with startling effect. Raven is a fine stuffed bird surmounted by a garland of flowers which is suspended by attaching the silk ribbons to garland at sides opposite the bird's mouth. These ribbons are double and contain a rubber tube, the ends of which are concealed among the flowers. Assistant behind sings, speaks and whistles into a metallic chamber connected with one of the tubes, the sound passing out in a direct line with bird's mouth, apparently coming from it.

## ***Samuel's Cartomantic Floral Charm***

A pack of cards transformed to a profusion of flowers.

**Secret--**A hollow metal fake pack is loaded with spring flowers, (roses) having a loop at end, hanging out, and through which performer passes his thumb, and produces flowers, vanishing pack up sleeve by the usual clip.

## ***Samuel's Mystic Percolator***

A glass percolator (two gallon size) is used for this experiment. Percolator is shown to company perfectly empty, covered with a shallow silver cover, and given to a lady or gentleman to hold upright. A large silk handkerchief is thrown over it to exclude the light. Performer now empties a cornucopia of paper roses, which were a few moments before mysteriously produced from cone, right into tube of his blunderbuss, (large size tube) and shoots flowers into the percolator, where they are found as soon as the handkerchief is removed from it.

Flowers are concealed inside silver lid of percolator (on principle of coin cork) so that pressing a small projecting pin on top of cover when throwing handkerchief over it, the trap door bottom gives way and the spring flowers fall out, a spiral spring closing door again.

## ***Samuel's Wonder Kraut***

A cabbage is transformed to an Aquarium containing live fish. A small aquarium having mouth closed by rubber cap, same as fish-bowl trick, is inserted inside an artificial cabbage, made of cloth, or cloth and rubber, nicely painted to resemble the genuine article. Colored silk handkerchief is thrown over cabbage and both covers removed at the same time.

## ***Samuel's Magic Squeezers***

Performer, during the performance of some trick, requires a glass of wine, taking a deck of cards in hand he squeezes them tightly several times until a whole glass of wine is extracted from them.

**Secret--**There is a faked deck, picked up with four or five cards in front to spread out to prove genuineness. Remove pellet of wax or wooden plug from air hole and wine runs out of small hole in bottom of fake. The fake pack is made of tin, having nicely painted edges and real cards glued on front and back. Fill fake with a small fine-tubed syringe. A very effective trick used in conjunction with flying glass of water or wine.

## ***Samuel's Wine Tassels***

Two tassels hang in any appropriate place on the stage, apparently for mere drapery effect. They are made to resemble the ordinary heavy, every-day tassel, used to tie up heavy curtains, etc. The body of tassel is hollow spun metal of sufficient capacity to contain a full glass of wine. Air hole in top of fake. Plug in bottom drawn out of fake by performer pulling smartly on thread which hangs below tassel, at a very short distance thread is not visible.

An extraordinary improvement can be made by having a rubber tube covered to represent cord, connected with one of these tassels by an opening made in the top of the hollow receptacle. Rubber tube fitting over a hollow metal connection.



## ***Samuel's Bloodstone Wonder***

A large white stone is inspected. Performer remarks that the old adage declares that you cannot get blood out of a stone, but this is now made possible by the Charmed bloodstone. Here he taps the stone several times with the hollow metal wand, at third blow wand and stone are lowered over a tray on table and blood pours from the stone into a glass tumbler on tray. Blood comes from wand. Blood is then vanished by vanishing glass of water, etc.

Stone is wrapped in paper and the package exchanged on servante for one containing a loaf of bread of same size, this is placed on run down. Performer fires wand at package, opens it and states that Satan has commanded the stone to change to bread. This bread can contain previously borrowed articles, or cards to be produced from it.

## ***Samuel's Handkerchief Tassel***

Tassel is made similar to wine tassel, except a slight alteration in base, this one. being perfectly open. When performer desires a large and beautiful silk handkerchief, he simply puts his finger through a loop at end of a silk thread hanging a few inches below the fringe of tassel and while calling attention to something in the air, he makes a downward sweep of the right hand instantly disclosing the handkerchief, flag, glove, etc., silk ribbons or anything else capable of being hidden beneath its mystic recess.

## ***Samuel's Golden Flash of Light***

A ladies' handkerchief is borrowed, ring for flash handkerchief of same size. Handkerchief is ignited and disappears instantly in a flash leaving in sight nothing but a heap of gold coins in performer's hand.

Purchase from Western News Co. a Columbus souvenir pile of gold coins sold for paper weights, attach a cat gut or wire loop to it and suspend it on back of left hand, under cover of flash handkerchief, swing it into palm, when you place handkerchief there to vanish.